



FrameLink Express™

User's Manual

CONFIDENTIAL NOTICE:

Copyright ©2008, Imperx, Inc. All rights reserved.
Any unauthorized use, duplication or distribution of this document or any part thereof,
without the prior written consent of Imperx Corporation is strictly prohibited.

Revision History

Revision History			
RA01	Aug-12-2008	J. Egri	Initial Release
RA02	Nov-24-2008	J. Egri	Updated Table 2a for 'unpacked' modes and added Tables 2b thru 2e for 'packed' modes. Updated 'Camera Parameters' dialog to include 'packed' option. Updated 'Statistics' dialog to include clock_rate, horiz. and vert. fields
RA03	Dec-04-2008	J. Egri	Updated Appendix A.
RA04	June-24-2009	J. Egri	Updated Software Installation to reflect new InstallShield for Windows 64 bit OS.
RA05	July-12-2011	J. Egri	Added Medium mode support. Added PCIe and ExpressCard/34 versions.

Table Of Contents

CHAPTER 1 - INTRODUCTION.....	5
FRAMELINK EXPRESS.....	6
WHAT YOU NEED TO GET STARTED.....	19
INSPECTING THE FRAMELINK EXPRESS PACKAGE	20
CHAPTER 2 – HARDWARE INSTALLATION	21
CHAPTER 3 – SOFTWARE INSTALLATION	22
SOFTWARE SUITE	22
SOFTWARE INSTALLATION FROM CD	24
SOFTWARE UPGRADE FROM WEB SITE.....	28
FIRMWARE UPGRADE FROM WEB SITE.....	29
CHAPTER 4 – USING THE FRAMELINK EXPRESS	30
RUNNING THE FRAMELINK EXPRESS APPLICATION.....	31
MAIN WINDOW	32
CAMERA PARAMETERS DIALOG	37
CC CONTROL DIALOG.....	43
RGB CONTROL DIALOG.....	46
CAPTURE SETTINGS DIALOG	47
TERMINAL DIALOG.....	57
STATISTICS DIALOG	58
HEX PIXEL DUMP WINDOW.....	60
HISTOGRAM WINDOW	62
LOOKUP TABLE DIALOG.....	70
ZOOM MENU	71
PLAYER CONTROL.....	72
PLAYER DIALOG.....	74
CHAPTER 5 – ELECTRICAL INTERFACES.....	75
CAMERA LINK CONNECTOR	76
EXPRESSCARD CONNECTOR	77
PCIe x1 CONNECTOR.....	78
CHAPTER 6 - SPECIFICATIONS.....	79
APPENDIX A – SERIAL COMMUNICATIONS.....	80
APPENDIX B – CREATING LOOK UP TABLES.....	81

Illustrations

Figure 1 – FrameLink Express Block Diagram	8
Figure 2a – Camera Link Interface (connector #1).....	9
Figure 2b – Camera Link Interface (connector #2).....	10

Tables

Table 1 – CameraLink modes.....	11
Table 2 – Image data bit-to-port assignments per the Camera Link specification - Base modes	12
Table 3 – Image data bit-to-port assignments per the Camera Link specification - Medium modes.....	12
Table 4 – Unpacked pixel mapping into memory.....	13
Table 5a – Packed pixel mapping into memory – 8 bit modes	14
Table 5b – Packed pixel mapping into memory – 1x10, 2x10 and 3x10 modes – 6 pixels/DW	15
Table 5c – Packed pixel mapping into memory – 4x10 mode – 12 pixels/2 DWs	15
Table 5d – Packed pixel mapping into memory – 1x12 mode – 5 pixels/DW	16
Table 5e – Packed pixel mapping into memory – 2x12 mode – 16 pixels/3 DWs	16
Table 5f – Packed pixel mapping into memory – 3x12 mode – 15 pixels/3 DWs.....	16
Table 5g – Packed pixel mapping into memory – 4x12 mode – 16 pixels/3 DWs.....	16
Table 5h – Packed pixel mapping into memory – RGB24 mode – 8 pixels/3 DWs.....	17
Table 5i – Packed pixel mapping into memory – RGB30 mode – 2 pixels/DW	17
Table 5j – Packed pixel mapping into memory – RGB36 mode – 5 pixels/3 DWs.....	17
Table 6 – Camera Link Connector Pin-out	76
Table 7 – ExpressCard Connector Pin-out	77
Table 8 – PCIe x1 Connector Pin-out.....	78

Chapter

1



Introduction

This chapter outlines the key features of the Imperx FrameLink Express card.



FrameLink Express

The FrameLink Express frame grabber comes in three versions:

- 1 - a dual-channel low-profile x1 PCI Express card
- 2 - a dual-channel ExpressCard/54 card
- 3 - a single-channel ExpressCard/34 card

The dual-channel cards provide two Camera Link interfaces while the single-channel card provides only one. The dual-channel cards provide the ability to capture digital video data from two 'base' configuration Camera Link interfaces or a single 'medium' interface while the single-channel card provides the ability to capture digital video data from only one 'base' configuration Camera Link interface. All cards transfer the video data to host memory via a PCI Express x1 interface. All of the cards share the same software (ie. application program, libraries and driver). The remaining text in this document makes reference to a dual-channel card but note that the single-channel card is just a one channel version of this same card.

Functionality

- Captures video data from two Base Camera Link interfaces or a single Medium Camera Link interface, formats this data and stores it into local FIFO's.
- Retrieves the formatted data from the FIFO's and transfers it into host memory via an intelligent scatter/gather DMA over the PCI Express interface.
- Provides a full-duplex asynchronous interface (UART) to/from an attached device on each Camera Link serial interface.
- Provides the host processor with the ability to configure the four discrete Camera Control signals on each Camera Link interface.

Interfaces

Camera Link interface

The FrameLink Express provides two Camera Link interfaces that follow the 'base' or 'medium' configuration, as defined in the Camera Link standard, requiring two 26 conductor connectors/cables (refer to Figures 2a and 2b). The 'base' configuration consists of multiplexing 28 bits of video data into 4 LVDS data streams. This data consists of 24 bits of pixel data along with 4 pixel qualifier signals: 'line valid' strobe, 'frame valid' strobe, 'data valid' strobe and a spare strobe (for future use). A phased-

locked transmit clock is transmitted in parallel with the data streams over a fifth LVDS link. Additionally, four RS-644 LVDS streams (CC[4:1]) are included for general purpose camera control. These 'camera control' signals allow the frame grabber to manipulate discrete controls within an attached camera. A bi-directional asynchronous communications channel between the frame grabber and an attached camera is also provided by means of two RS-644 LVDS pairs. The 'medium' configuration consist of two 'base' configurations with the exception that the second interface does not include the general purpose camera control signals and the communications channel.

PCI Express interface

The FrameLink Express PCIe card complies with the x1 low-profile PCI Express add-in card dimensions as defined in the PCI Express Card Electromechanical Specification revision 2.0.

The FrameLink Express/54 and FrameLink Express/34 cards comply with the ExpressCard/54 and ExpressCard/34 package dimensions, respectively, as defined in the ExpressCard Standard release 1.2. Both cards include a 37mm x 20mm extension area used to house the CameraLink connectors.

The FrameLink Express provides a 2.5 GHz PCIe Master/Target interface compliant with the PCI Express Release 1.2 specification. This interface provides a single 'function', as defined in the PCI Express specification. The design does not support any memory mapped or I/O mapped peripherals on card. Access to the FrameLink Express's FIFOs is achieved through DMA operations that move the data from the FIFOs into host memory. The host cannot directly access the contents of the FIFOs. The design supports host access into configuration registers, DMA registers, local registers and CIS data via configuration space accesses.

A functional block diagram of the FrameLink Express card is illustrated in Figure 1.

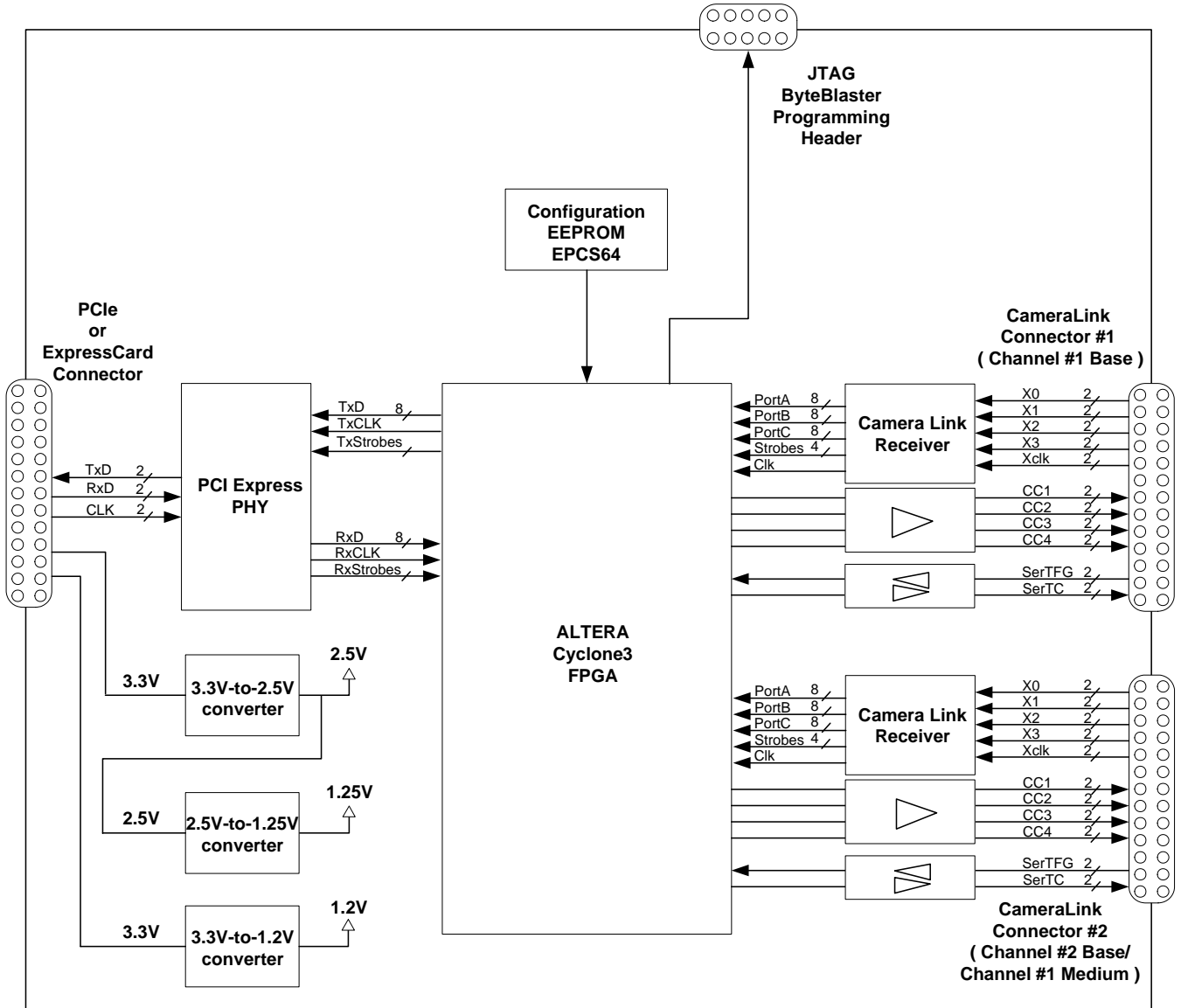

Figure 1 – FrameLink Express Block Diagram

A functional block diagram of the Camera Link interface is illustrated in Figures 2a and 2b.

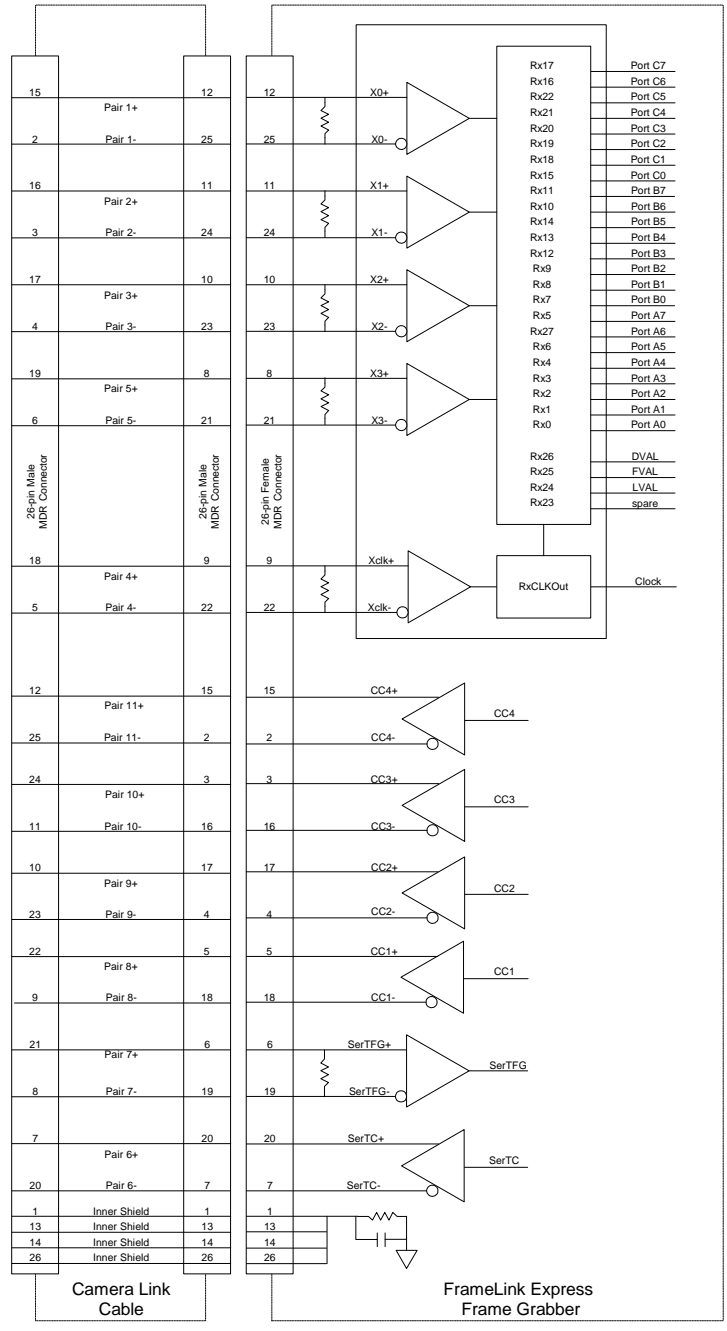

Figure 2a – Camera Link Interface (connector #1)

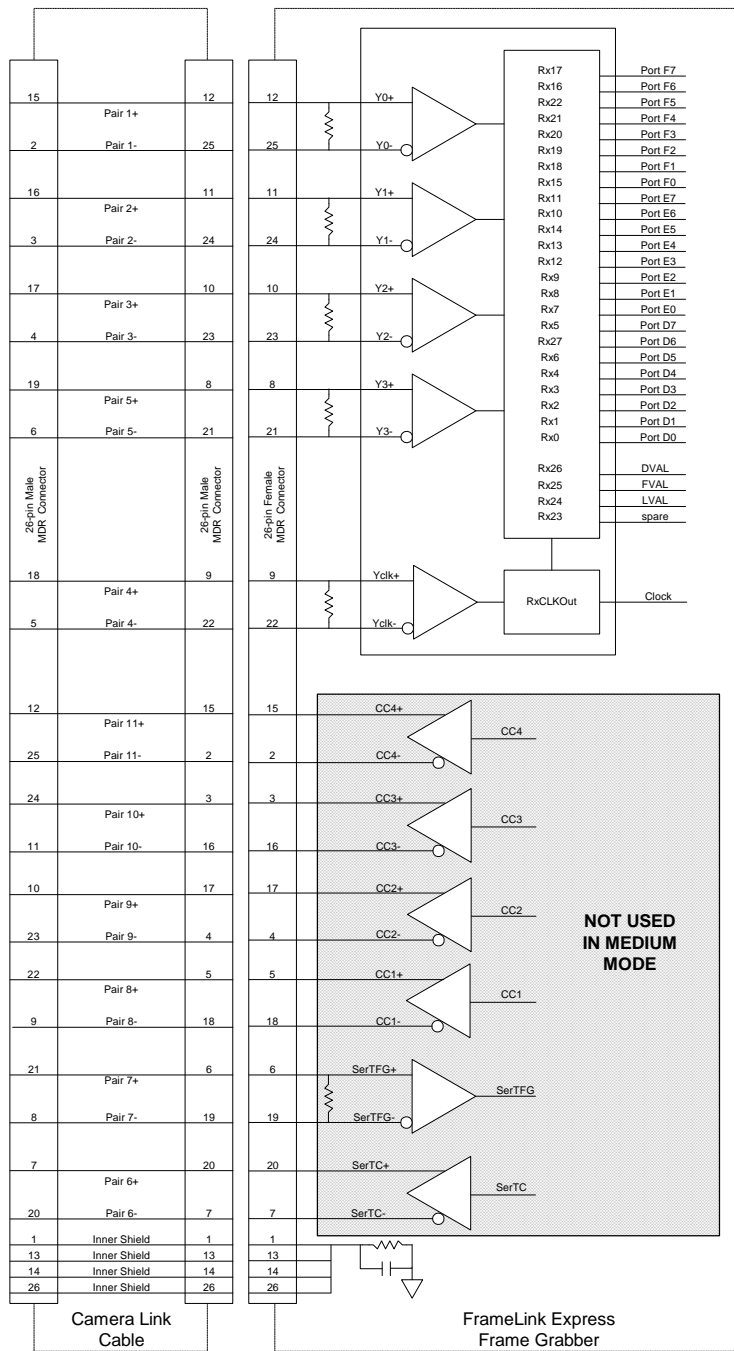

Figure 2b – Camera Link Interface (connector #2)

Video Capture

The video capture engine is responsible for receiving video pixel data and qualifiers from the Camera Link transceivers, formatting the data and transferring it into on-board memory. It supports all CameraLink modes as defined in Table 1 for Base and Medium configurations. Seventeen different modes of operation are supported as indicated in the table. The data that it receives from the Camera Link transceivers, per the Camera Link specification, is illustrated in Table 2 and Table 3 for Base and Medium modes, respectively.

The video capture engine translates this data into doublewords (64 bits), as defined in Table 4 and Tables 5a–5j. These tables reflect how the data will appear in host memory. Two options are provided: un-packed and packed. When ‘un-packed’ is selected, the data is formatted per Table 4. When ‘packed’ is selected, the data is formatted per Tables 5a thru 5j. Packing uses the PCI Express bandwidth more efficiently and conserves memory space.

1x8	2x8	3x8	1x10	2x10	1x12	2x12	1x14	1x16	RGB24	4x8	3x10	4x10	3x12	4x12	RGB30	RGB36	MODE
✓	✓	✓	✓	✓	✓	✓	✓	✓	✓								Base
										✓	✓	✓	✓	✓	✓	✓	Medium

Table 1 – CameraLink modes

Port C								Port B								Port A								MODE		
c7	c6	c5	c4	c3	c2	c1	c0	b7	b6	b5	b4	b3	b2	b1	b0	a7	a6	a5	a4	a3	a2	a1	a0			
																A7	A6	A5	A4	A3	A2	A1	A0	1x8		
C7	C6	C5	C4	C3	C2	C1	C0	B7	B6	B5	B4	B3	B2	B1	B0	A7	A6	A5	A4	A3	A2	A1	A0	2x8		
																A7	A6	A5	A4	A3	A2	A1	A0	3x8		
																A9	A8							1x10		
B7	B6	B5	B4	B3	B2	B1	B0			B9	B8			A9	A8	A7	A6	A5	A4	A3	A2	A1	A0	2x10		
																A7	A6	A5	A4	A3	A2	A1	A0	1x12		
B7	B6	B5	B4	B3	B2	B1	B0	B11	B10	B9	B8	A11	A10	A9	A8	A7	A6	A5	A4	A3	A2	A1	A0	2x12		
												A13	A12	A11	A10	A9	A8	A7	A6	A5	A4	A3	A2	A1	A0	1x14
																		A15	A14	A13	A12	A11	A10	A9	A8	1x16
BL7	BL6	BL5	BL4	BL3	BL2	BL1	BL0	GR7	GR6	GR5	GR4	GR3	GR2	GR1	GR0	RD7	RD6	RD5	RD4	RD3	RD2	RD1	RD0	RGB24		

Table 2 – Image data bit-to-port assignments per the Camera Link specification - Base modes

Port C								Port B								Port A								MODE
Port F								Port E								Port D								
c7	c6	c5	c4	c3	c2	c1	c0	b7	b6	b5	b4	b3	b2	b1	b0	a7	a6	a5	a4	a3	a2	a1	a0	
f7	f6	f5	f4	f3	f2	f1	f0	e7	e6	e5	e4	e3	e2	e1	e0	d7	d6	d5	d4	d3	d2	d1	d0	4x8
C7	C6	C5	C4	C3	C2	C1	C0	B7	B6	B5	B4	B3	B2	B1	B0	A7	A6	A5	A4	A3	A2	A1	A0	4x8
																D7	D6	D5	D4	D3	D2	D1	D0	
																A7	A6	A5	A4	A3	A2	A1	A0	3x10
						C9	C8	C7	C6	C5	C4	C3	C2	C1	C0									
B7	B6	B5	B4	B3	B2	B1	B0			B9	B8			A9	A8	A7	A6	A5	A4	A3	A2	A1	A0	4x10
		D9	D8			C9	C8	C7	C6	C5	C4	C3	C2	C1	C0	D7	D6	D5	D4	D3	D2	D1	D0	
B7	B6	B5	B4	B3	B2	B1	B0	B11	B10	B9	B8	A11	A10	A9	A8	A7	A6	A5	A4	A3	A2	A1	A0	3x12
				C11	C10	C9	C8	C7	C6	C5	C4	C3	C2	C1	C0									
B7	B6	B5	B4	B3	B2	B1	B0	B11	B10	B9	B8	A11	A10	A9	A8	A7	A6	A5	A4	A3	A2	A1	A0	4x12
D11	D10	D9	D8	C11	C10	C9	C8	C7	C6	C5	C4	C3	C2	C1	C0	D7	D6	D5	D4	D3	D2	D1	D0	
BL7	BL6	BL5	BL4	BL3	BL2	BL1	BL0			BL9	BL8			RD9	RD8	RD7	RD6	RD5	RD4	RD3	RD2	RD1	RD0	RGB30
						GR9	GR8	GR7	GR6	GR5	GR4	GR3	GR2	GR1	GR0									
BL7	BL6	BL5	BL4	BL3	BL2	BL1	BL0	BL11	BL10	BL9	BL8	RD11	RD10	RD9	RD8	RD7	RD6	RD5	RD4	RD3	RD2	RD1	RD0	RGB36
				GR11	GR10	GR9	GR8	GR7	GR6	GR5	GR4	GR3	GR2	GR1	GR0									

Table 3 – Image data bit-to-port assignments per the Camera Link specification - Medium modes

Byte4								Byte3								Byte 2								Byte1								MODE	Base	Med		
d31	d30	d29	d28	d27	d26	d25	d24	d23	d22	d21	d20	d19	d18	d17	d16	d15	d14	d13	d12	d11	d10	d9	d8	d7	d6	d5	d4	d3	d2	d1	d0					
A7	A6	A5	A4	A3	A2	A1	A0	A7	A6	A5	A4	A3	A2	A1	A0	A7	A6	A5	A4	A3	A2	A1	A0	A7	A6	A5	A4	A3	A2	A1	A0	1x8	✓			
B7	B6	B5	B4	B3	B2	B1	B0	A7	A6	A5	A4	A3	A2	A1	A0	B7	B6	B5	B4	B3	B2	B1	B0	A7	A6	A5	A4	A3	A2	A1	A0	2x8	✓			
-	-	-	-	-	-	-	-	C7	C6	C5	C4	C3	C2	C1	C0	B7	B6	B5	B4	B3	B2	B1	B0	A7	A6	A5	A4	A3	A2	A1	A0	3x8	✓			
D7	D6	D5	D4	D3	D2	D1	D0	C7	C6	C5	C4	C3	C2	C1	C0	B7	B6	B5	B4	B3	B2	B1	B0	A7	A6	A5	A4	A3	A2	A1	A0	4x8		✓		
-	-	-	-	-	-	A9	A8	A7	A6	A5	A4	A3	A2	A1	A0	-	-	-	-	-	-	-	A9	A8	A7	A6	A5	A4	A3	A2	A1	A0	1x10	✓		
-	-	-	-	-	-	B9	B8	B7	B6	B5	B4	B3	B2	B1	B0	-	-	-	-	-	-	-	A9	A8	A7	A6	A5	A4	A3	A2	A1	A0	2x10	✓		
-	-	-	-	-	-	B9	B8	B7	B6	B5	B4	B3	B2	B1	B0	-	-	-	-	-	-	-	A9	A8	A7	A6	A5	A4	A3	A2	A1	A0	3x10		✓	
-	-	-	-	-	-	B9	B8	B7	B6	B5	B4	B3	B2	B1	B0	-	-	-	-	-	-	-	A9	A8	A7	A6	A5	A4	A3	A2	A1	A0	4x10		✓	
-	-	-	-	A11	A10	A9	A8	A7	A6	A5	A4	A3	A2	A1	A0	-	-	-	-	-	A11	A10	A9	A8	A7	A6	A5	A4	A3	A2	A1	A0	1x12	✓		
-	-	-	-	B11	B10	B9	B8	B7	B6	B5	B4	B3	B2	B1	B0	-	-	-	-	-	A11	A10	A9	A8	A7	A6	A5	A4	A3	A2	A1	A0	2x12	✓		
-	-	-	-	B11	B10	B9	B8	B7	B6	B5	B4	B3	B2	B1	B0	-	-	-	-	-	A11	A10	A9	A8	A7	A6	A5	A4	A3	A2	A1	A0	3x12		✓	
-	-	-	-	B11	B10	B9	B8	B7	B6	B5	B4	B3	B2	B1	B0	-	-	-	-	-	A11	A10	A9	A8	A7	A6	A5	A4	A3	A2	A1	A0	4x12		✓	
-	-	-	A13	A12	A11	A10	A9	A8	A7	A6	A5	A4	A3	A2	A1	A0	-	-	-	A13	A12	A11	A10	A9	A8	A7	A6	A5	A4	A3	A2	A1	A0	1x14	✓	
A15	A14	A13	A12	A11	A10	A9	A8	A7	A6	A5	A4	A3	A2	A1	A0	A15	A14	A13	A12	A11	A10	A9	A8	A7	A6	A5	A4	A3	A2	A1	A0	1x16	✓			
-	-	-	-	-	-	-	-	RD	RD	RD	RD	RD	RD	RD	RD	GR	GR	GR	GR	GR	GR	GR	GR	BL	BL	BL	BL	BL	BL	BL	BL	RGB24	✓			
-	-	-	-	-	-	GR	GR	GR	GR	GR	GR	GR	GR	GR	GR	-	-	-	-	-	-	BL	BL	BL	BL	BL	BL	BL	BL	BL	BL	RGB30		✓		
-	-	-	-	GR	GR	GR	GR	GR	GR	GR	GR	GR	GR	GR	GR	-	-	-	-	BL	BL	BL	BL	BL	BL	BL	BL	BL	BL	BL	BL	RGB36		✓		

Byte8								Byte7								Byte6								Byte5								MODE	Base	Med		
d63	d62	d61	d60	d59	d58	d57	d56	d55	d54	d53	d52	d51	d50	d49	d48	d47	d46	d45	d44	d43	d42	d41	d40	d39	d38	d37	d36	d35	d34	d33	d32					
A7	A6	A5	A4	A3	A2	A1	A0	A7	A6	A5	A4	A3	A2	A1	A0	A7	A6	A5	A4	A3	A2	A1	A0	A7	A6	A5	A4	A3	A2	A1	A0	1x8	✓			
B7	B6	B5	B4	B3	B2	B1	B0	A7	A6	A5	A4	A3	A2	A1	A0	B7	B6	B5	B4	B3	B2	B1	B0	A7	A6	A5	A4	A3	A2	A1	A0	2x8	✓			
-	-	-	-	-	-	-	-	C7	C6	C5	C4	C3	C2	C1	C0	B7	B6	B5	B4	B3	B2	B1	B0	A7	A6	A5	A4	A3	A2	A1	A0	3x8	✓			
D7	D6	D5	D4	D3	D2	D1	D0	C7	C6	C5	C4	C3	C2	C1	C0	B7	B6	B5	B4	B3	B2	B1	B0	A7	A6	A5	A4	A3	A2	A1	A0	4x8		✓		
-	-	-	-	-	-	A9	A8	A7	A6	A5	A4	A3	A2	A1	A0	-	-	-	-	-	-	-	A9	A8	A7	A6	A5	A4	A3	A2	A1	A0	1x10	✓		
-	-	-	-	-	-	B9	B8	B7	B6	B5	B4	B3	B2	B1	B0	-	-	-	-	-	-	-	A9	A8	A7	A6	A5	A4	A3	A2	A1	A0	2x10	✓		
-	-	-	-	-	-	-	-	-	-	-	-	-	-	-	-	-	-	-	-	-	-	-	C9	C8	C7	C6	C5	C4	C3	C2	C1	C0	3x10		✓	
-	-	-	-	-	-	D9	D8	D7	D6	D5	D4	D3	D2	D1	D0	-	-	-	-	-	-	-	C9	C8	C7	C6	C5	C4	C3	C2	C1	C0	4x10		✓	
-	-	-	-	A11	A10	A9	A8	A7	A6	A5	A4	A3	A2	A1	A0	-	-	-	-	-	A11	A10	A9	A8	A7	A6	A5	A4	A3	A2	A1	A0	1x12	✓		
-	-	-	-	B11	B10	B9	B8	B7	B6	B5	B4	B3	B2	B1	B0	-	-	-	-	-	A11	A10	A9	A8	A7	A6	A5	A4	A3	A2	A1	A0	2x12	✓		
-	-	-	-	-	-	-	-	-	-	-	-	-	-	-	-	-	-	-	-	-	C11	C10	C9	C8	C7	C6	C5	C4	C3	C2	C1	C0	3x12		✓	
-	-	-	-	D11	D10	D9	D8	D7	D6	D5	D4	D3	D2	D1	D0	-	-	-	-	-	C11	C10	C9	C8	C7	C6	C5	C4	C3	C2	C1	C0	4x12		✓	
-	-	-	A13	A12	A11	A10	A9	A8	A7	A6	A5	A4	A3	A2	A1	A0	-	-	-	A13	A12	A11	A10	A9	A8	A7	A6	A5	A4	A3	A2	A1	A0	1x14	✓	
A15	A14	A13	A12	A11	A10	A9	A8	A7	A6	A5	A4	A3	A2	A1	A0	A15	A14	A13	A12	A11	A10	A9	A8	A7	A6	A5	A4	A3	A2	A1	A0	1x16	✓			
-	-	-	-	-	-	-	-	RD	RD	RD	RD	RD	RD	RD	RD	GR	GR	GR	GR	GR	GR	GR	GR	BL	BL	BL	BL	BL	BL	BL	BL	RGB24	✓			
-	-	-	-	-	-	-	-	-	-	-	-	-	-	-	-	-	-	-	-	-	-	RD	RD	RD	RD	RD	RD	RD	RD	RD	RD	RGB30		✓		
-	-	-	-	-	-	-	-	-	-	-	-	-	-	-	-	-	-	-	-	RD	RD	RD	RD	RD	RD	RD	RD	RD	RD	RD	RD	RGB36		✓		

Table 4 – Unpacked pixel mapping into memory

d31	d30	d29	d28	d27	d26	d25	d24	d23	d22	d21	d20	d19	d18	d17	d16	d15	d14	d13	d12	d11	d10	d9	d8	d7	d6	d5	D4	d3	d2	d1	d0	
d63	d62	d61	d60	d59	d58	d57	d56	d55	d54	d53	d52	d51	d50	d49	d48	d47	d46	d45	d44	d43	d42	d41	d40	d39	d38	d37	d36	d35	d34	d33	d32	MODE
A1	A0	A9	A8	A7	A6	A5	A4	A3	A2	A1	A0	A9	A8	A7	A6	A5	A4	A3	A2	A1	A0	A9	A8	A7	A6	A5	A4	A3	A2	A1	A0	1x10
-	-	-	-	A9	A8	A7	A6	A5	A4	A3	A2	A1	A0	A9	A8	A7	A6	A5	A4	A3	A2	A1	A0	A9	A8	A7	A6	A5	A4	A3	A2	
B1	B0	A9	A8	A7	A6	A5	A4	A3	A2	A1	A0	B9	B8	B7	B6	B5	B4	B3	B2	B1	B0	A9	A8	A7	A6	A5	A4	A3	A2	A1	A0	2x10
-	-	-	-	B9	B8	B7	B6	B5	B4	B3	B2	B1	B0	A9	A8	A7	A6	A5	A4	A3	A2	A1	A0	B9	B8	B7	B6	B5	B4	B3	B2	
A1	A0	C9	C8	C7	C6	C5	C4	C3	C2	C1	C0	B9	B8	B7	B6	B5	B4	B3	B2	B1	B0	A9	A8	A7	A6	A5	A4	A3	A2	A1	A0	3x10
-	-	-	-	C9	C8	C7	C6	C5	C4	C3	C2	C1	C0	B9	B8	B7	B6	B5	B4	B3	B2	B1	B0	A9	A8	A7	A6	A5	A4	A3	A2	

Table 5b – Packed pixel mapping into memory – 1x10, 2x10 and 3x10 modes – 6 pixels/DW

	31	30	29	28	27	26	25	24	23	22	21	20	19	18	17	16	15	14	13	12	11	10	9	8	7	6	5	4	3	2	1	0	
	63	62	61	60	59	58	57	56	55	54	53	52	51	50	49	48	47	46	45	44	43	42	41	40	39	38	37	36	35	34	33	32	MODE
DW1	D1	D0	C9	C8	C7	C6	C5	C4	C3	C2	C1	C0	B9	B8	B7	B6	B5	B4	B3	B2	B1	B0	A9	A8	A7	A6	A5	A4	A3	A2	A1	A0	4x10
DW1	C3	C2	C1	C0	B9	B8	B7	B6	B5	B4	B3	B2	B1	B0	A9	A8	A7	A6	A5	A4	A3	A2	A1	A0	D9	D8	D7	D6	D5	D4	D3	D2	
DW2	B5	B4	B3	B2	B1	B0	A9	A8	A7	A6	A5	A4	A3	A2	A1	A0	D9	D8	D7	D6	D5	D4	D3	D2	D1	D0	C9	C8	C7	C6	C5	C4	
DW2	-	-	-	-	-	-	-	-	D9	D8	D7	D6	D5	D4	D3	D2	D1	D0	C9	C8	C7	C6	C5	C4	C3	C2	C1	C0	B9	B8	B7	B6	

Table 5c – Packed pixel mapping into memory – 4x10 mode – 12 pixels/2 DWs

d31	d30	d29	d28	d27	d26	d25	d24	d23	d22	d21	d20	d19	d18	d17	d16	d15	d14	d13	d12	d11	d10	d9	d8	d7	d6	d5	D4	d3	d2	d1	d0	
d63	d62	d61	d60	d59	d58	d57	d56	d55	d54	d53	d52	d51	d50	d49	d48	d47	d46	d45	d44	d43	d42	d41	d40	d39	d38	d37	d36	d35	d34	d33	d32	MODE
A7	A6	A5	A4	A3	A2	A1	A0	A11	A10	A9	A8	A7	A6	A5	A4	A3	A2	A1	A0	A11	A10	A9	A8	A7	A6	A5	A4	A3	A2	A1	A0	1x12
-	-	-	-	A11	A10	A9	A8	A7	A6	A5	A4	A3	A2	A1	A0	A11	A10	A9	A8	A7	A6	A5	A4	A3	A2	A1	A0	A11	A10	A9	A8	

Table 5d – Packed pixel mapping into memory – 1x12 mode – 5 pixels/DW

	31	30	29	28	27	26	25	24	23	22	21	20	19	18	17	16	15	14	13	12	11	10	9	8	7	6	5	4	3	2	1	0	
	63	62	61	60	59	58	57	56	55	54	53	52	51	50	49	48	47	46	45	44	43	42	41	40	39	38	37	36	35	34	33	32	MODE
DW1	A7	A6	A5	A4	A3	A2	A1	A0	B11	B10	B9	B8	B7	B6	B5	B4	B3	B2	B1	B0	A11	A10	A9	A8	A7	A6	A5	A4	A3	A2	A1	A0	2x12
DW1	B3	B2	B1	B0	A11	A10	A9	A8	A7	A6	A5	A4	A3	A2	A1	A0	B11	B10	B9	B8	B7	B6	B5	B4	B3	B2	B1	B0	A11	A10	A9	A8	
DW2	B11	B10	B9	B8	B7	B6	B5	B4	B3	B2	B1	B0	A11	A10	A9	A8	A7	A6	A5	A4	A3	A2	A1	A0	B11	B10	B9	B8	B7	B6	B5	B4	
DW2	A7	A6	A5	A4	A3	A2	A1	A0	B11	B10	B9	B8	B7	B6	B5	B4	B3	B2	B1	B0	A11	A10	A9	A8	A7	A6	A5	A4	A3	A2	A1	A0	
DW3	B3	B2	B1	B0	A11	A10	A9	A8	A7	A6	A5	A4	A3	A2	A1	A0	B11	B10	B9	B8	B7	B6	B5	B4	B3	B2	B1	B0	A11	A10	A9	A8	
DW3	B11	B10	B9	B8	B7	B6	B5	B4	B3	B2	B1	B0	A11	A10	A9	A8	A7	A6	A5	A4	A3	A2	A1	A0	B11	B10	B9	B8	B7	B6	B5	B4	

Table 5e – Packed pixel mapping into memory – 2x12 mode – 16 pixels/3 DWs

	31	30	29	28	27	26	25	24	23	22	21	20	19	18	17	16	15	14	13	12	11	10	9	8	7	6	5	4	3	2	1	0	
	63	62	61	60	59	58	57	56	55	54	53	52	51	50	49	48	47	46	45	44	43	42	41	40	39	38	37	36	35	34	33	32	MODE
DW1	C7	C6	C5	C4	C3	C2	C1	C0	B11	B10	B9	B8	B7	B6	B5	B4	B3	B2	B1	B0	A11	A10	A9	A8	A7	A6	A5	A4	A3	A2	A1	A0	3x12
DW1	C3	C2	C1	C0	B11	B10	B9	B8	B7	B6	B5	B4	B3	B2	B1	B0	A11	A10	A9	A8	A7	A6	A5	A4	A3	A2	A1	A0	C11	C10	C9	C8	
DW2	B11	B10	B9	B8	B7	B6	B5	B4	B3	B2	B1	B0	A11	A10	A9	A8	A7	A6	A5	A4	A3	A2	A1	A0	C11	C10	C9	C8	C7	C6	C5	C4	
DW2	B7	B6	B5	B4	B3	B2	B1	B0	A11	A10	A9	A8	A7	A6	A5	A4	A3	A2	A1	A0	C11	C10	C9	C8	C7	C6	C5	C4	C3	C2	C1	C0	
DW3	B3	B2	B1	B0	A11	A10	A9	A8	A7	A6	A5	A4	A3	A2	A1	A0	C11	C10	C9	C8	C7	C6	C5	C4	C3	C2	C1	C0	B11	B10	B9	B8	
DW3	-	-	-	-	-	-	-	-	-	-	-	-	C11	C10	C9	C8	C7	C6	C5	C4	C3	C2	C1	C0	B11	B10	B9	B8	B7	B6	B5	B4	

Table 5f – Packed pixel mapping into memory – 3x12 mode – 15 pixels/3 DWs

	31	30	29	28	27	26	25	24	23	22	21	20	19	18	17	16	15	14	13	12	11	10	9	8	7	6	5	4	3	2	1	0	
	63	62	61	60	59	58	57	56	55	54	53	52	51	50	49	48	47	46	45	44	43	42	41	40	39	38	37	36	35	34	33	32	MODE
DW1	C7	C6	C5	C4	C3	C2	C1	C0	B11	B10	B9	B8	B7	B6	B5	B4	B3	B2	B1	B0	A11	A10	A9	A8	A7	A6	A5	A4	A3	A2	A1	A0	4x12
DW1	B3	B2	B1	B0	A11	A10	A9	A8	A7	A6	A5	A4	A3	A2	A1	A0	D11	D10	D9	D8	D7	D6	D5	D4	D3	D2	D1	D0	C11	C10	C9	C8	
DW2	D11	D10	D9	D8	D7	D6	D5	D4	D3	D2	D1	D0	C11	C10	C9	C8	C7	C6	C5	C4	C3	C2	C1	C0	B11	B10	B9	B8	B7	B6	B5	B4	
DW2	C7	C6	C5	C4	C3	C2	C1	C0	B11	B10	B9	B8	B7	B6	B5	B4	B3	B2	B1	B0	A11	A10	A9	A8	A7	A6	A5	A4	A3	A2	A1	A0	
DW3	B3	B2	B1	B0	A11	A10	A9	A8	A7	A6	A5	A4	A3	A2	A1	A0	D11	D10	D9	D8	D7	D6	D5	D4	D3	D2	D1	D0	C11	C10	C9	C8	
DW3	D11	D10	D9	D8	D7	D6	D5	D4	D3	D2	D1	D0	C11	C10	C9	C8	C7	C6	C5	C4	C3	C2	C1	C0	B11	B10	B9	B8	B7	B6	B5	B4	

Table 5g – Packed pixel mapping into memory – 4x12 mode – 16 pixels/3 DWs

	31	30	29	28	27	26	25	24	23	22	21	20	19	18	17	16	15	14	13	12	11	10	9	8	7	6	5	4	3	2	1	0		
	63	62	61	60	59	58	57	56	55	54	53	52	51	50	49	48	47	46	45	44	43	42	41	40	39	38	37	36	35	34	33	32	MODE	
DW1	B7	B6	B5	B4	B3	B2	B1	B0	R7	R6	R5	R4	R3	R2	R1	R0	G7	G6	G5	G4	G3	G2	G1	G0	B7	B6	B5	B4	B3	B2	B1	B0	RGB	
DW1	G7	G6	G5	G4	G3	G2	G1	G0	B7	B6	B5	B4	B3	B2	B1	B0	R7	R6	R5	R4	R3	R2	R1	R0	G7	G6	G5	G4	G3	G2	G1	G0	24	
DW2	R7	R6	R5	R4	R3	R2	R1	R0	G7	G6	G5	G4	G3	G2	G1	G0	B7	B6	B5	B4	B3	B2	B1	B0	R7	R6	R5	R4	R3	R2	R1	R0		
DW2	B7	B6	B5	B4	B3	B2	B1	B0	R7	R6	R5	R4	R3	R2	R1	R0	G7	G6	G5	G4	G3	G2	G1	G0	B7	B6	B5	B4	B3	B2	B1	B0		
DW3	G7	G6	G5	G4	G3	G2	G1	G0	B7	B6	B5	B4	B3	B2	B1	B0	R7	R6	R5	R4	R3	R2	R1	R0	G7	G6	G5	G4	G3	G2	G1	G0		
DW3	R7	R6	R5	R4	R3	R2	R1	R0	G7	G6	G5	G4	G3	G2	G1	G0	B7	B6	B5	B4	B3	B2	B1	B0	R7	R6	R5	R4	R3	R2	R1	R0		

Table 5h – Packed pixel mapping into memory – RGB24 mode – 8 pixels/3 DWs

d31	d30	d29	d28	d27	d26	d25	d24	d23	d22	d21	d20	d19	d18	d17	d16	d15	d14	d13	d12	d11	d10	d9	d8	d7	d6	d5	d4	d3	d2	d1	d0		
d63	d62	d61	d60	d59	d58	d57	d56	d55	d54	d53	d52	d51	d50	d49	d48	d47	d46	d45	d44	d43	d42	d41	d40	d39	d38	d37	d36	d35	d34	d33	d32	MODE	
-	-	R9	R8	R7	R6	R5	R4	R3	R2	R1	R0	G9	G8	G7	G6	G5	G4	G3	G2	G1	G0	B9	B8	B7	B6	B5	B4	B3	B2	B1	B0	RGB	
-	-	R9	R8	R7	R6	R5	R4	R3	R2	R1	R0	G9	G8	G7	G6	G5	G4	G3	G2	G1	G0	B9	B8	B7	B6	B5	B4	B3	B2	B1	B0	30	

Table 5i – Packed pixel mapping into memory – RGB30 mode – 2 pixels/DW

	31	30	29	28	27	26	25	24	23	22	21	20	19	18	17	16	15	14	13	12	11	10	9	8	7	6	5	4	3	2	1	0		
	63	62	61	60	59	58	57	56	55	54	53	52	51	50	49	48	47	46	45	44	43	42	41	40	39	38	37	36	35	34	33	32	MODE	
DW1	R7	R6	R5	R4	R3	R2	R1	R0	G11	G10	G9	G8	G7	G6	G5	G4	G3	G2	G1	G0	B11	B10	B9	B8	B7	B6	B5	B4	B3	B2	B1	B0	RGB	
DW1	R3	R2	R1	R0	G11	G10	G9	G8	G7	G6	G5	G4	G3	G2	G1	G0	B11	B10	B9	B8	B7	B6	B5	B4	B3	B2	B1	B0	R11	R10	R9	R8	36	
DW2	G11	G10	G9	G8	G7	G6	G5	G4	G3	G2	G1	G0	B11	B10	B9	B8	B7	B6	B5	B4	B3	B2	B1	B0	R11	R10	R9	R8	R7	R6	R5	R4		
DW2	G7	G6	G5	G4	G3	G2	G1	G0	B11	B10	B9	B8	B7	B6	B5	B4	B3	B2	B1	B0	R11	R10	R9	R8	R7	R6	R5	R4	R3	R2	R1	R0		
DW3	G3	G2	G1	G0	B11	B10	B9	B8	B7	B6	B5	B4	B3	B2	B1	B0	R11	R10	R9	R8	R7	R6	R5	R4	R3	R2	R1	R0	G11	G10	G9	G8		
DW3	-	-	-	-	-	-	-	-	-	-	-	-	R11	R10	R9	R8	R7	R6	R5	R4	R3	R2	R1	R0	G11	G10	G9	G8	G7	G6	G5	G4		

Table 5j – Packed pixel mapping into memory – RGB36 mode – 5 pixels/3 DWs

Pixel Buffering	The pixel data formatted by the video capture engine is stored into two on-board FIFO memories. This memory serves as an elastic store for formatted video pixel data. The FIFOs are managed by an independent pair of controllers, implemented in the FPGA, supporting concurrent operation. The two FIFOs are utilized in a ping-pong fashion such that while one is being filled with new pixel data, the other is being emptied via DMA into host memory.
DMA	The DMA engine is responsible for reading formatted pixel data from the on-board FIFO memories and transferring them into host memory via the PCI Express interface. An intelligent scatter-gather method is utilized, providing for an efficient use of the PCI Express bandwidth. The use of non-contiguous 4Kbyte buffers provides support for the Windows operating system's memory allocation model.
Serial Interface	A bi-directional Universal Asynchronous Receiver Transmitter (UART) is provided for each Camera Link serial interface. It transmits and receives ASYNC formatted characters with 1 Start bit, 8 data bits, no parity and 1 Stop bit. The baud rate of this interface can be configured by the user to be any one of a set of standard bit rates ranging from 4800 to 115.2K bits per second. A software interface to the UART is provided by means of a Camera Link compliant ' <i>clser***.dll</i> ' file.
Camera Control	The FrameLink Express card provides four discrete camera control bits per the Camera Link specification for each channel. These bits can be configured by the user via the FrameLink Express application GUI.
FPGA	The heart of the FrameLink Express is a dense Field Programmable Gate Array (FPGA). This FPGA implements all of the functions related to video data capture, formatting, storage and DMA. The firmware contents of the FPGA can be upgraded while in the field by following the instruction outlined in Section 3 of this document entitled 'Firmware Upgrade from Web Site'.

What you need to get started

To begin using the FrameLink Express card, you need the following:

- A computer with a PCIe x1 slot or a laptop with an ExpressCard/54 (or ExpressCard/34) slot.
- Microsoft Windows XP or 2000 software.
- A computer with at least 256M bytes of RAM.
- A CD drive, and a hard disk on which to install the FrameLink Express software.

Inspecting the FrameLink Express package

When you unpack your FrameLink Express package, you should visually inspect all of its contents. If something is missing or damaged, contact your Imperx representative.

Package contents

You should have received the following items:

- The FrameLink Express card
- A CD with the FrameLink Express software suite
- A 'Quick Start' installation guide

Chapter 2

Hardware Installation

Installing the FrameLink Express card is as simple as plugging it into an available PCIe x1 slot on your desktop computer's motherboard or a ExpressCard/54 (or ExpressCard/34) slot on your laptop.

Chapter 3

Software Installation

This chapter explains how to install the FrameLink Express software.

Software Suite

The FrameLink Express software suite consists of the following files:

Windows application files:

(located in *c:\Program Files\ImperX\FrameLink Express*)

FrameLink_Express.exe	- Area scan application program
VceComEx.exe	- Virtual COM port emulator
FrameLink_Express.chm	- Help file
FrameLinkConsole.exe	- Console program (for debug purposes)
FLExDrvManager.exe	- Driver manager tool (for debug purposes)
Uninstall.exe	- Un-install utility
VCECLB.dll	- FrameLink Express library
clsripix.dll	- CameraLink serial interface library
ippLib.dll	- Intel image processing library
IpxLog.dll	- ImperX logging library
IpxMisc.dll	- ImperX miscellaneous library
IpxMovieMaker.dll	- ImperX movie maker library
DSMovieWriter.ax	- Movie Writer DirectShow filter

Windows driver files:

(located in *c:\Program Files\ImperX\FrameLink Express\drivers*)

/Kernel/ folder	- WinXP/2000/Vista driver files
/DirectShow/ folder	- DirectX driver files

/Halcon/ folder - Halcon driver files
/Labview/ folder - Labview driver files

Software Development Kit (SDK) files:
(located in *c:\Program Files\ImperX\FrameLink Express\SDK*)

/bin/ folder - binaries
/inc/ folder - include files
/lib/ folder - libraries
/doc/ folder - documentation
/examples/ folder - sample source code

Documentation files:
(located in *c:\Program Files\ImperX\FrameLink Express\Doc*)

FrameLink_Express_Users_Manual.pdf - User manual document
FrameLink_Express_Datasheet.pdf - Technical datasheet

LUT Files:
(located in *c:\Program Files\ImperX\FrameLink Express\LUT*)

gamma_45.lut - Sample lookup table for Gamma_45
gamma_45.xls - Sample excel file for Gamma_45

CAM Files:
(located in *c:\Program Files\ImperX\FrameLink Express\CAM_Files*)

various folders - FrameLink Express configuration files for various
camera vendors

Note that our FrameLink Express application program was created using our SDK (software developers kit). Our SDK is included in the standard FrameLink Express software suite that comes with the card.

Software Installation from CD

Use the following steps to install the FrameLink Express software supplied on a CD. Note that 'click' refers to the left mouse button.

1. If a version of FrameLink Express was previously installed on this machine, then you must first remove it:

To remove the application files:

- 1.1 Click on "*Start*".
 - 1.2 Click on "*Settings*".
 - 1.3 Click on "*Control Panel*".
 - 1.4 Double click on "*Add or Remove Programs*".
 - 1.5 Click on "*FrameLink Express*".
 - 1.6 Click on "*Remove*".
 - 1.7 If the 'FrameLink Express – InstallShield Wizard' pops-up then do the following, otherwise go to step 1.8
 - Click on '*Remove*'.
 - Click '*Next*'.
 - Click '*Yes*'.
 - Click '*Finish*'.
 - 1.8 Click on "*Yes*".
 - 1.9 Click on "*Close*".
2. After having removed a previous version or if a version of FrameLink Express was NOT previously installed on this machine then:

The first step is to install the application files:

- 2.1 Insert the FrameLink Express CD into the appropriate drive; the setup.exe file will run automatically. Note: If it does not start automatically, then click on "*Start*", "*Run*", enter or browse to "*(CD drive): setup.exe*" and click "*OK*".
- 2.2 Wait for the "FrameLink Express - InstallShield Wizard" screen to appear.
- 2.3 Follow the on-screen instructions.
- 2.4 For Windows XP 32 bit and Windows XP 64 bit, click "*Continue Anyway*" to continue.



- 2.5 For Windows Vista 32 bit and Windows Vista 64 bit, select “*Always trust software from Imperx, Inc.*” and click on “*Install*” button, when the following message appears:

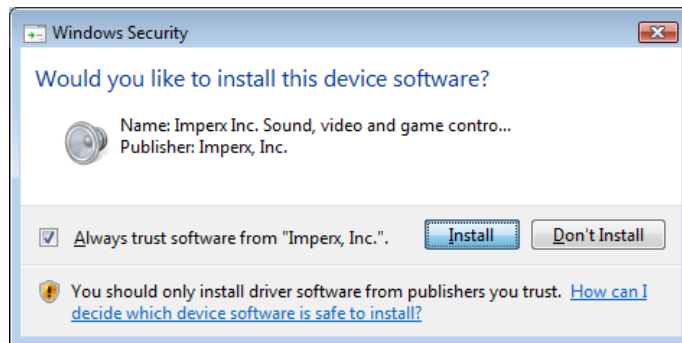

- 2.6 When the following message appears, choose if you would like to register online by clicking on “*Register now*” or “*Skip*”.

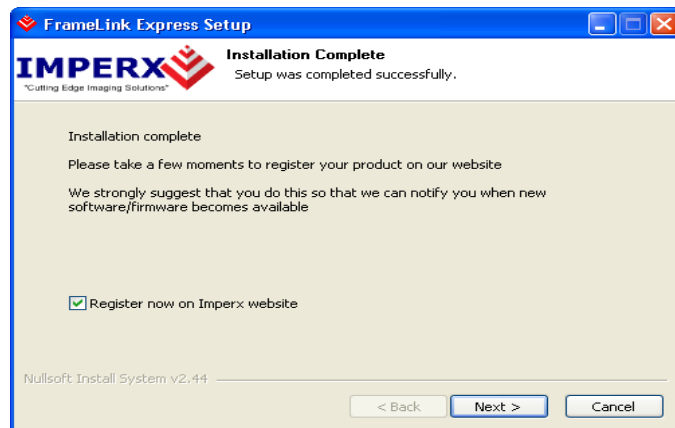

- 2.7 Click “*Finish*”. This completes the software installation.
- 2.8 Reboot your computer.

The next step is to install the driver files:

- 2.9 Insert the FrameLink Express card into the computer.
- 2.10 For Windows XP 32 bit and for Windows XP 64 bit:
 - Wait for the system to prompt you with a “Found New Hardware Wizard” dialog box.
 - Proceed to Step 2.11.
- For Windows Vista:
 - The driver will automatically be installed.
 - Proceed to step 2.16.
- 2.11 Under certain conditions, the following message may appear:



If this message appears, click “*No, not this time*”, then click “*Next*”.

- 2.12 When the following message appears, select “*Install the software automatically (Recommended)*”, then click “*Next*”.

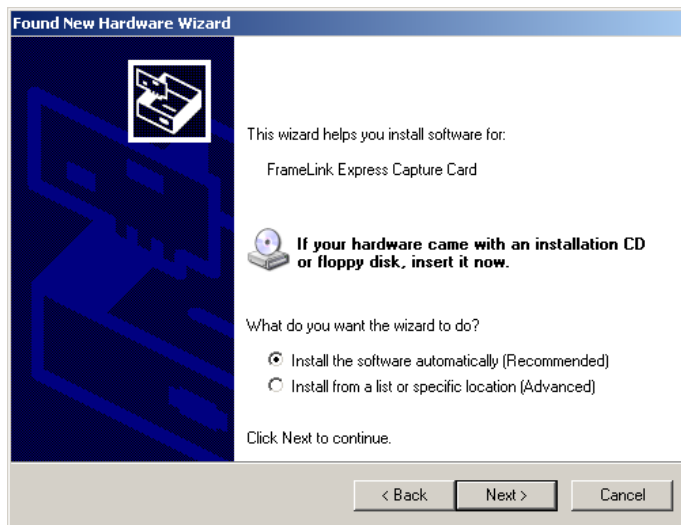

2.13 The following message will appear:



2.14 Click "*Continue Anyway*" to continue.

2.15 When "Click finish to close the wizard" appears, click on "*Finish*".

2.16 This completes the driver installation.

Software Upgrade from Web Site

New application and/or driver software may be released periodically to reflect improvements and/or functionality added to the FrameLink Express. You can retrieve these updates by visiting the download page of our web site at

http://www.imperx.com/frame_grabbers/camera_link/FrameLink_Express_downloads.php

Use the following steps to install newly released application software:

- 3.1 Uninstall all application files by following the instructions in step 1. of the 'Software Installation from CD' section.
- 3.2 Download the FrameLink_Express_Installer.exe file from the Imperx web site to a new folder on your PC (we will use the folder C:\new_FrameLink Express as an example).
- 3.3 Left mouse click on "*Start*", "*Run*", enter or browse to *C:\new_FrameLink Express\Framelink_Express_Installer.exe*.
- 3.4 Left mouse click on "*Open*", then "*OK*".
- 3.5 Follow the instructions starting from step 2.2 above.

Firmware Upgrade from Web Site

Your newly received FrameLink Express card has been programmed in the factory with the latest firmware prior to shipping. New firmware, however, may be released periodically to reflect improvements and/or added functionality. You can retrieve these updates by visiting the download page of our web site at:

http://www.imperx.com/frame_grabbers/camera_link/FrameLink Express_downloads.php

Use the following steps to install newly released firmware:

1. Download and unzip the firmware Upgrade Utility file to a folder on your PC.
2. Insert the FrameLink Express card into the laptop. Note that if your system has two ExpressCard slots, then you must insert the card into the slot in which it was placed during the original driver installation.
3. If the system prompts you with a “New Hardware Found” dialog box, then you have not previously installed the driver. You must follow the steps outlined in the section above titled “Software Installation from CD” to install the driver.
4. To run the Upgrade Utility simply double click on the icon.
Note: DO NOT POWER DOWN OR REMOVE THE CARD WHILE PROGRAMMING IS IN PROGRESS!
5. The Upgrade Utility will display the following dialog box:

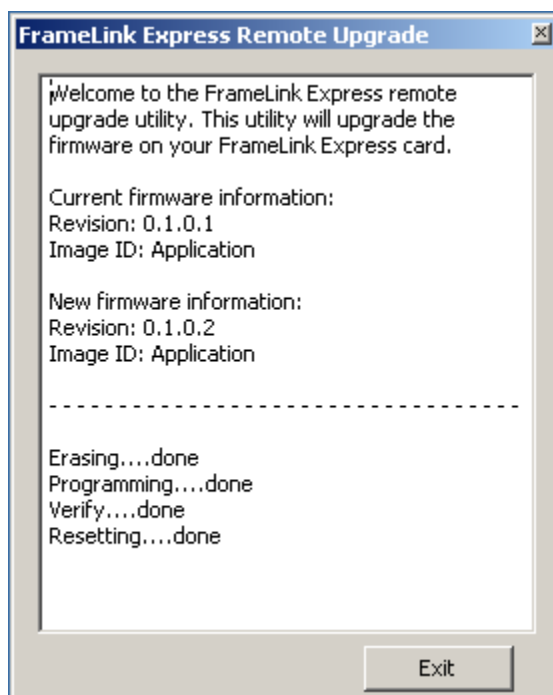

Chapter **4**



Using the FrameLink Express

This chapter contains information on how to configure and use the FrameLink Express card.

Running the FrameLink Express Application

The VCECLB_app.exe program supplied with the FrameLink Express card is a stand-alone Windows based application. It provides an easy to use graphical user interface (GUI), allowing the user to configure the FrameLink Express card and to view, record and playback video data received from the CameraLink interface. The application consists of a main window as well as several other dialogs which can be accessed from the main menu or from convenient icons.

Launching Application

To launch the FrameLink Express application, simply double left mouse click on the 'FrameLink Express' icon on the desktop.



Note

In the remainder of this chapter, references to 'clicking' on objects in the GUI refers to the left mouse button.

Main Window

When the FrameLink Express application is executed, a main window titled 'FrameLink Express' will appear. The main window provides the primary area for viewing real-time images received from the camera. This window can be sized and moved to suit your needs. When image viewing is active, the size of this window will be automatically scaled as a function of the camera parameters (i.e. pixels/line and lines/frame) specified in the 'Camera Parameters' dialog.

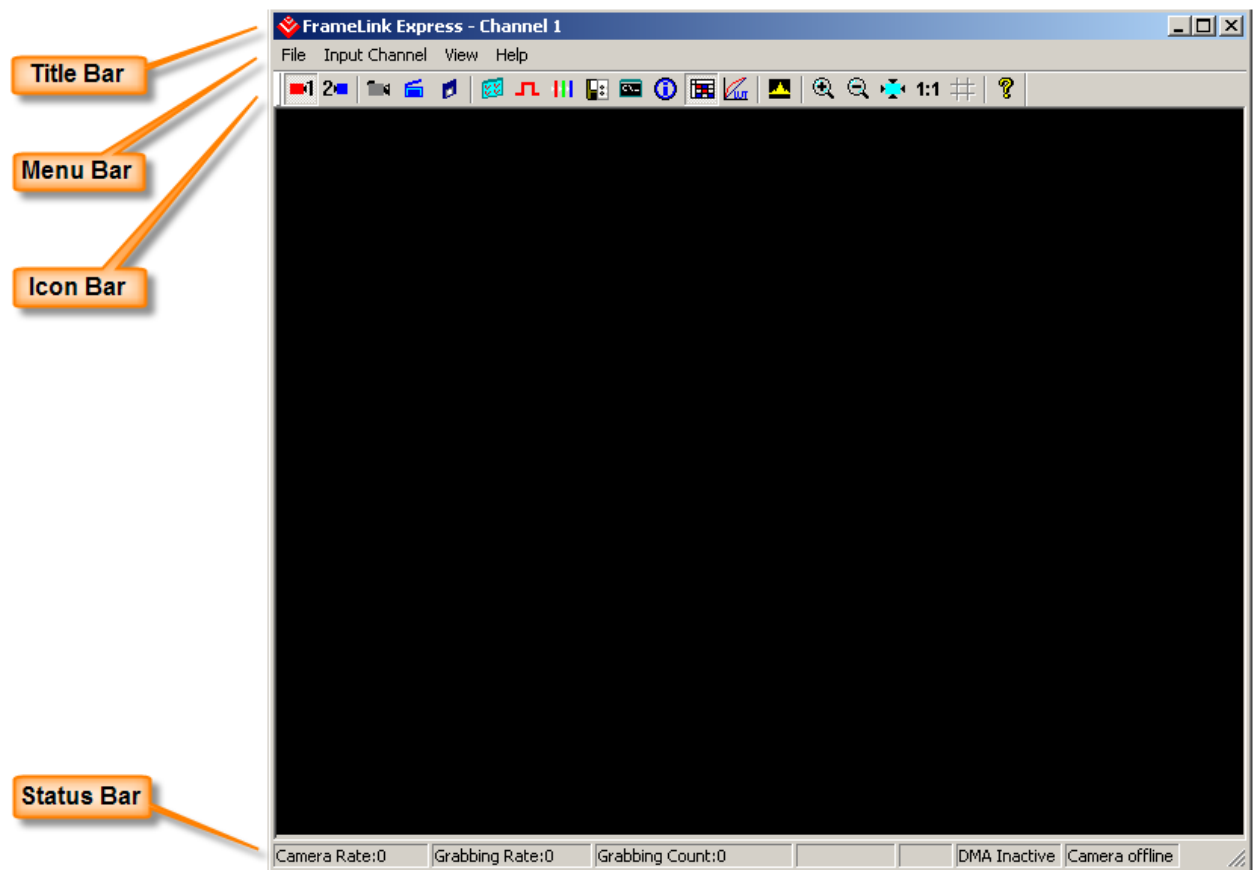

The Main dialog contains a Title bar, a Menu bar, an Icon bar and a Status bar.

Title Bar	The Title bar reflects the name assigned to the Camera Link port that is currently selected. A name of 'Channel 1' or 'Channel 2' is used as a default. The user can replace this default name by filling in the 'Alias' field in the 'Camera Parameters' dialog.
Menu Bar	The Menu bar includes a set of pull-down sub-menus as follows:
File	Clicking on this item reveals a pull-down menu with two options: 'Player' and 'Exit'.
Play Files	This option opens the 'Player Dialog' and 'Player Control' windows.
Exit	Clicking on this option causes the program to terminate.
Input Channel	Reveals a pull-down menu allowing the user to select which Camera Link channel to connect to.
View	Clicking on this item reveals a pull-down menu with the following options:
Camera Parameters	Causes the 'Camera Parameters' dialog to appear.
CC Control	Causes the 'CC Control' dialog to appear.
RGB Control	Causes the 'RGB Control' dialog to appear. This option is only available if 'Bayer' or 'RGB' is selected in the 'video type' field of the 'Camera Parameters' dialog.
Capture Settings	Causes the 'Capture Settings' dialog to appear.
Terminal	Causes the 'Terminal' dialog to appear.
Statistics	Causes the 'Statistics' dialog to appear.
Hex Pixel Dump	Causes the 'Hex Pixel Dump' dialog to appear.
Histogram	Causes the 'Histogram' dialog to appear.
Lookup Table	Causes the 'Lookup Table' dialog to appear.

Zoom Causes the 'Zoom' menu to appear.





















Help Clicking on this item reveals a pull-down menu with two options: 'About' and 'Help Manual'.

About Causes version information to be displayed including release identifiers for the application software, library, driver and firmware. This information should be provided to Imperx technical support personnel during a service call.

Help Manual Causes an interactive point-and-click style help manual to be displayed. The help manual provides a summary description of all GUI controls and fields.

Icon Bar

The Icon bar contains a set of icons that act as shortcuts into the features located on the Menu bar.

	Select Channel #1
	Select Channel #2
	Start/stop continuous Grab
	Snap single frame
	Start/stop Capture to disk
	Open Camera Parameters dialog
	Open CC Control dialog
	Open RGB Control dialog
	Open Capture Settings dialog
	Open Terminal dialog
	Open Statistics dialog
	Open Hex Pixel Dump dialog
	Open Histogram dialog
	Enable/disable Lookup Table processing
	Zoom 1:1
	Zoom In
	Zoom Out
	Fit to Window
	Turn Grid on/off
	Help

Status Bar

The Status bar reflects the real-time state of the current camera connection.

Camera Rate

Displays the real-time frame rate of the attached camera as measured at the input of the FrameLink Express card.

Grabbing Rate

Displays the real-time rate at which frames are being transferred from the card into host memory.

Grabbing Count

Displays a running count of the total number of frames transferred into system memory. This counter is reset when 'grabbing' is stopped.

DMA Status

Displays the real-time status of the DMA process as being either '**active**' or '**inactive**'.

'**Active**' indicates that the user has commanded the FrameLink Express to acquire video data by clicking on the 'Start Grab' button and that the camera is providing valid framing.

'**Inactive**' indicates that either the user has commanded the FrameLink Express to stop acquiring video data by clicking on the 'Stop Grab' button or that grabbing is enabled but the camera is not providing valid framing.

Camera Status

Displays the real-time status of the attached camera as being either '**online**' or '**offline**'.

'**Online**' indicates that the camera is powered on, attached and providing a video clock via the CameraLink interface.

'**Offline**' indicates that the FrameLink Express card is not receiving a video clock from the camera either because the camera is powered off or the CameraLink cable is disconnected.

Camera Parameters Dialog

The Camera Parameters dialog allows the user to configure the FrameLink Express card with the operating parameters of the attached camera. For the FrameLink Express card to be able to properly acquire and display images from an attached camera, the settings entered into this screen must match the parameters of the camera.

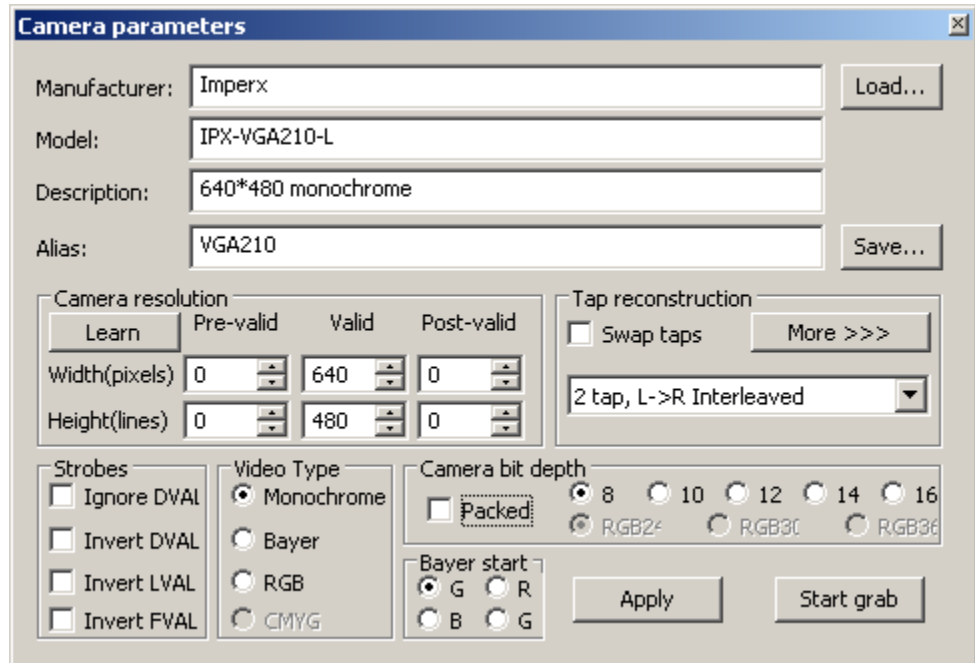

**Manufacturer
Model
Description**

These text fields allow the user to record the vendor and part number of the attached camera. This text, along with all of the other settings, can then be saved as a .CXF file on the PC for later retrieval.

Alias

This is a user defined name for the channel. The text entered into this field will be displayed as the channel name in the Title bar.

Load...

Loads a previously saved camera configuration file. Clicking on this box will cause a Windows 'browse' box to appear. The user can then browse to the folder and file he wishes to open. The program will then open the selected file, parse it and populate the fields in the dialog.

Save...

Saves the current GUI fields as a camera configuration file. Clicking on this box will cause a Windows 'browse' box to appear. The user can then browse to a folder and enter a file name. The program will then create a .CXF file using the values in the dialog's fields and write it to the disk.

Camera Resolution

These fields specify the geometry of the attached camera and instructs the FrameLink Express on how to reconstruct a received image.

Width (pixels): These fields specify the total number of pixels per line. The Camera Link standard defines a line as being a series of pixels enveloped by the LVAL strobe and qualified by the DVAL strobe. Cameras generally provide some leading and trailing dummy pixels before and after a set of valid pixels. Most cameras can disqualify these dummy pixels by negating the DVAL signal. For cameras that do not disqualify the dummy pixels, the FrameLink Express has to be told the number of pre-valid, valid and post-valid pixels in order to properly construct an image.

Pre-valid Specifies the number of leading pixels prior to any valid pixels. The FrameLink Express will exclude these pixels from the displayed/captured image.

Valid Specifies the number of valid pixels. The FrameLink Express will include these pixels in the displayed/captured image.

Post-valid Specifies the number of trailing pixels following any valid pixels. The FrameLink Express will exclude these pixels from the displayed/captured image.

Height (lines): These fields specify the total number of lines per frame. The Camera Link standard defines a frame as being a series of lines enveloped by the FVAL strobe. Cameras can sometimes provide some leading and trailing dummy lines before and after a set of valid lines. Most cameras can disqualify these dummy lines by negating the FVAL signal. For cameras that do not disqualify the dummy lines, the FrameLink Express has to be told the number of pre-valid, valid and post-valid lines in order to properly construct an image.

Pre-valid Specifies the number of leading lines prior to any valid lines. The FrameLink Express will exclude these lines from the displayed/captured image.

Valid Specifies the number of valid lines. The FrameLink Express will include these lines in the displayed/captured image.

Post-valid

Specifies the number of trailing lines following any valid lines. The FrameLink Express will exclude these lines from the displayed/captured image.

Learn

Clicking on this button pops-up the ‘Auto learn’ dialog.

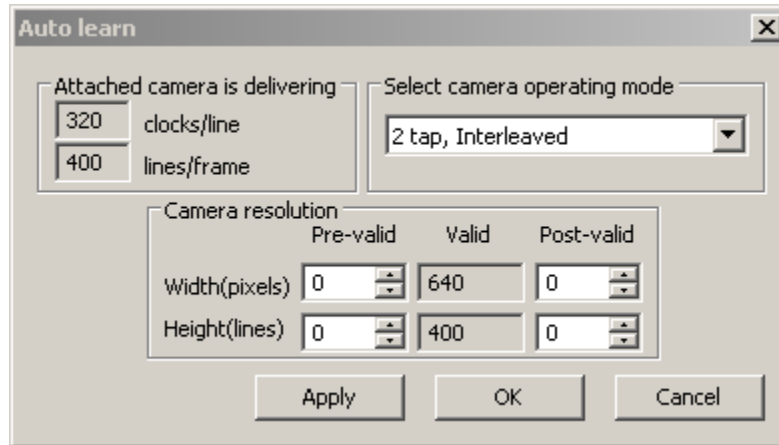

‘Auto learn’ is a unique feature of the FrameLink Express card which assists the user in entering the camera resolution parameters. The FrameLink Express card is continuously measuring the signals it receives from the CameraLink interface and therefore can determine what the cameras resolution is. It measures both the number of CLOCK transitions per LVAL (clocks/line) as well as the number of LVAL transitions per FVAL (lines/frame). It displays these results in the ‘Attached camera is delivering’ fields. The card, however, has no way of knowing how many taps are active and what the camera bit depth is. The user should select the operating mode of the camera and then click the ‘Apply’ button. This will cause the fields in the Camera Resolution group to automatically be populated.

NOTE: If the ‘clocks/line’ field is reporting a value of ‘0’, then the camera may not be providing a DVAL signal on the Camera Link interface. If this is the case then cancel the Auto Learn dialog, select ‘Ignore DVAL’ under Strobes in the Camera Parameters dialog and then click on ‘Learn’ again to re-enter the Auto Learn dialog.

Tap Reconstruction

Specifies the number of taps (channels) and the pixel ordering provided by the attached camera. The following formats are supported:

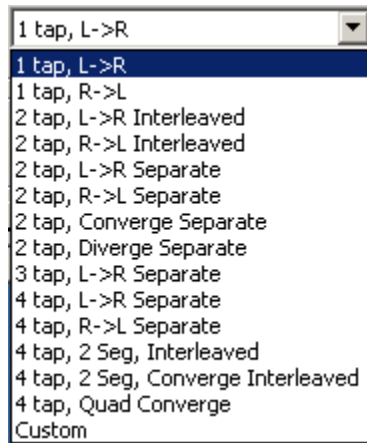

Swap taps

Instructs the card to interchange the pixel data received from Tap1 and Tap2 of the Camera Link interface. This only applies to Base modes.

More >>>

Clicking on this button will cause an animation of the selected tap reconstruction mode to appear.

Strobes

Specifies how to treat the Camera Link strobes, where 'DVAL' is data valid, 'LVAL' is line valid and 'FVAL' is frame valid.

Ignore DVAL

Instructs the FrameLink Express card to ignore the 'DVAL' signal received from the CameraLink interface. Pixel capture will be qualified with the 'FVAL' and 'LVAL' signals only.

Invert DVAL

Instructs the FrameLink Express card to invert the 'DVAL' signal received from the CameraLink interface prior to processing it.

Invert LVAL

Instructs the FrameLink Express card to invert the 'LVAL' signal received from the CameraLink interface prior to processing it.

Invert FVAL

Instructs the FrameLink Express card to invert the 'FVAL' signal received from the CameraLink interface prior to processing it.

Video Type

Specifies the video mode as either or monochrome, Bayer or RGB.

Camera Bit Depth

Specifies the number of bits per pixel.

Packed

Instructs the card to pack pixels before transferring them to host memory. Packing uses the PCI Express bandwidth more efficiently and conserves memory space. Refer to Tables 5a – 5j.

Bayer Start

Specifies the starting pixel in the bayer pattern as provided by the camera. This selection is typically required when a camera is operated with an 'area of interest' feature enabled. For the following examples, assume that 'n = number of pixels/line' and 'm = number of lines' then:

Pattern #1 Use this selection when the camera provides the following pattern:

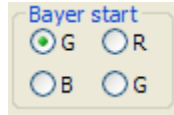

		Pixel						
		1	2	3	4	...	n-1	n
Line	1	G	R	G	R		G	R
	2	B	G	B	G		B	G
	3	G	R	G	R		G	R
	4	B	G	B	G		B	G
	:							
	m-1	G	R	G	R		G	R
	m	B	G	B	G		B	G

Pattern #2 Use this selection when the camera provides the following pattern:



		Pixel						
		1	2	3	4	...	n-1	n
Line	1	R	G	R	G		R	G
	2	G	B	G	B		G	B
	3	R	G	R	G		R	G
	4	G	B	G	B		G	B
	:							
	m-1	R	G	R	G		R	G
	m	G	B	G	B		G	B

Pattern #3 Use this selection when the camera provides the following pattern:



		Pixel						
		1	2	3	4	...	n-1	n
Line	1	B	G	B	G		B	G
	2	G	R	G	R		G	R
	3	B	G	B	G		B	G
	4	G	R	G	R		G	R
	:							
	m-1	B	G	B	G		B	G
	m	G	R	G	R		G	R

Pattern #4 Use this selection when the camera provides the following pattern:

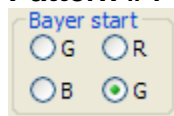

		Pixel						
		1	2	3	4	...	n-1	n
Line	1	G	B	G	B		G	B
	2	R	G	R	G		R	G
	3	G	B	G	B		G	B
	4	R	G	R	G		R	G
	:							
	m-1	G	B	G	B		G	B
	m	R	G	R	G		R	G

- Apply** Causes the application to apply the current settings to the FrameLink Express card.
- Start/Stop Grab** This button will toggle between **'Start Grab'** and **'Stop Grab'** every time the user clicks on it. Clicking on **'Start Grab'** enables the FrameLink Express's DMA engine and causes the main window to display live images received from the camera. Clicking on **'Stop Grab'** disables the DMA engine and causes the display to freeze.
- Close** This button will close the Camera Parameters dialog.

CC Control Dialog

The CC Control dialog allows the user to program the FrameLink Express card to generate signals on the Camera Link CC1-CC4 signals. These signals are often used by cameras to control triggering and exposure time via the host computer.

The FrameLink Express includes two pulse generators per channel: Master and Slave. Both pulse generator's outputs can be routed to the CC1-CC4 signals of either channel.

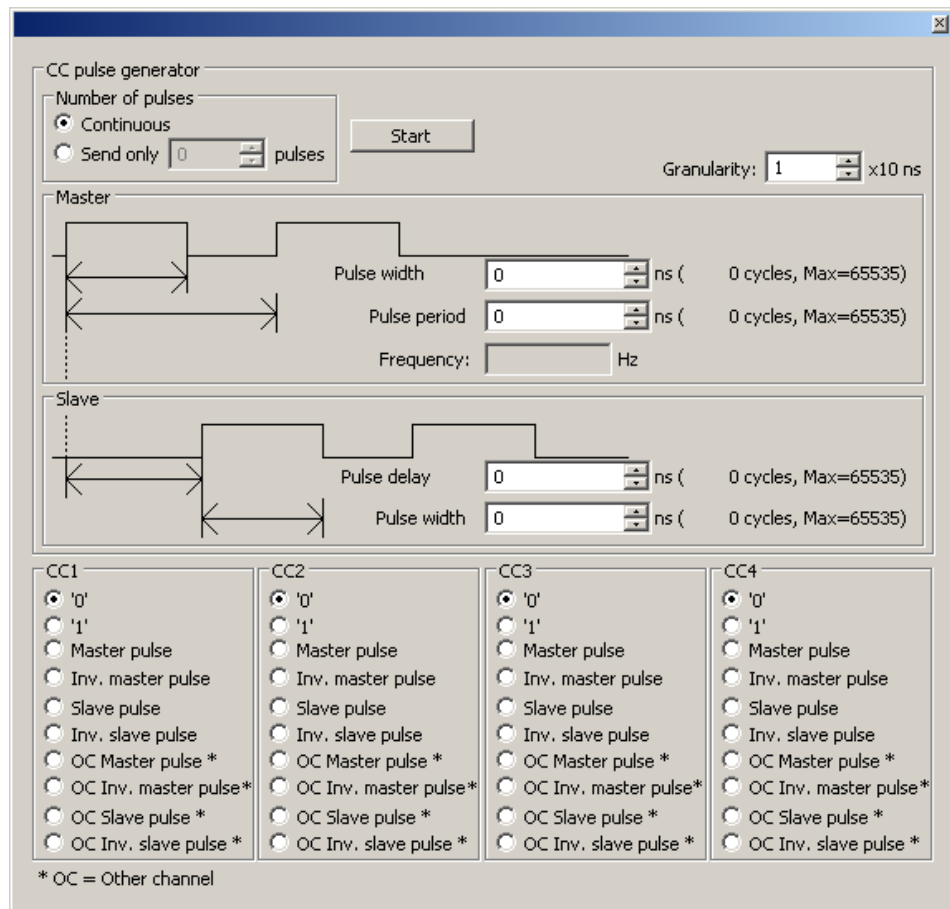

Start

This button toggles between 'Start' and 'Stop'. Causes both Master and Slave pulse generators to start or stop running.

Number of pulses:

Determines how often to send CC pulses:

Continuous

Configures the FrameLink Express to send a continuous stream of CC pulses. Clicking on the 'Start' button causes the pulses to begin. Clicking on the 'Stop' button causes the pulses to cease.

Send only	Configures the FrameLink Express to send a programmed number of pulses. Clicking on the ‘Start’ button causes the sequence to begin. The sequence will end after the programmed number of pulses are delivered.
Granularity	Sets the granularity of the clock used by the Master and Slave pulse generators. A value of ‘1’ corresponds to a clock period of 10 nSeconds, a value of ‘2’ to 20 nSeconds etc. All master and slave pulse variables (i.e. width, period, etc.) are scaled by this clock granularity.
Master	Sets the parameters for the Master pulse generator:
Pulse width	Sets the width of the master pulse.
Pulse period	Sets the period (repetition rate) of the master pulse.
Slave	Sets the parameters for the Slave pulse generator:
Pulse delay	Sets the delay between the master and slave pulses.
Pulse width	Sets the width of the slave pulse.
CC1 – CC4	Configures the behavior of each of the four CC signals:
‘0’	Drive the selected CC signal to a logic ‘0’.
‘1’	Drive the selected CC signal to a logic ‘1’.
Master pulse	Drive the selected CC signal with the output of the master pulse generator.
Inv. master Pulse	Drive the selected CC signal with the inverted output of the master pulse generator.
Slave pulse	Drive the selected CC signal with the output of the slave pulse generator.
Inv. slave Pulse	Drive the selected CC signal with the inverted output of the slave pulse generator.
OC Master pulse	Drive the selected CC signal with the output of the other channel’s master pulse generator.
OC Inv. master Pulse	Drive the selected CC signal with the inverted output of the other channel’s master pulse generator.

OC Slave pulse Drive the selected CC signal with the output of the other channel's slave pulse generator.

OC Inv. slave Pulse Drive the selected CC signal with the inverted output of the other channel's slave pulse generator.

RGB Control Dialog

The RGB Control dialog allows the user to adjust the gain and offset for each of the RGB color components. This option is only available if 'Bayer' or 'RGB' is selected in the 'video type' field of the 'Camera Parameters' dialog.

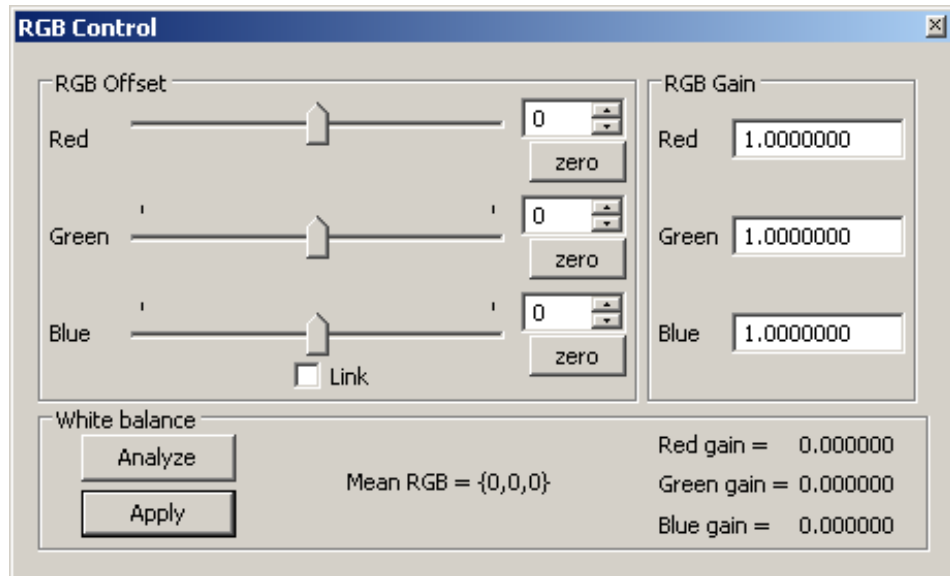

RGB Offset

Specifies the amount of offset to apply to each of the R, G and B components.

RGB Gain

Specifies the amount of gain to apply to each of the R, G and B components.

White balance

Performs an automatic white balancing procedure.

Analyze

Instructs the FrameLink Express card to analyze the current image received from the camera and to calculate a set of RGB Gain coefficients that will cause the sample image to be white balanced.

NOTE: Before clicking on 'Analyze', the user should point the camera at a uniform white target.

Apply

Instructs the FrameLink Express card to use the calculated RGB Gain coefficients acquired during the 'analyze' procedure and to apply these to the received image prior to display.

Capture Settings Dialog

This dialog gives the user complete control over image storage.

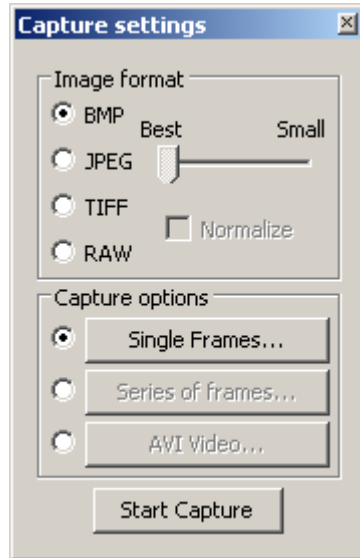

Start/Stop Capture

This button will toggle between **'Start Capture'** and **'Stop Capture'** every time the user clicks on it. Clicking on **'Start Capture'** starts the process of recording the images to disk. The options set in the **'Capture Options'** field determine what, how and when actual recording is performed. Clicking on **'Stop Capture'** causes recording to stop.

Close

This button will hide the Capture Settings Dialog screen. You can invoke it again by either hitting Ctrl-S or by selecting it from the Control Panel pull-down menu.

Image Format

When recording images to disk, this option selects the format, **'BMP'**, **'JPEG'**, **'TIFF'** or **'RAW'**, that the image will be saved in. Selecting **'JPEG'** activates a compression slider. **'Best'** provides the least compression, while **'Small'** provides the most compression.

Normalize

Normalize defines the way in which TIFF files are created. Since a TIFF file uses 16 bits to represent each pixel and cameras can produce less than 16 bit pixels, the normalize option is provided. If **'normalize'** is disabled, then left pixel padding is used so that 16 bit TIFF data is produced by appending zeros to the MSB bits of the pixel data. For example, for a 12 bit pixel the resultant 16 bit TIFF data is "0,0,0,0,p12, p11...p2,p1" where p12..p1 represent the 12 bit pixel. Left padding is useful when the user wishes to post-process the TIFF data. If **'normalize'** is enabled, then right pixel padding is used so that 16 bit TIFF data is

produced by shifting the pixel data left and appending zeros to the LSB bits of the pixel data. For example, for a 12 bit pixel the resultant 16 bit TIFF data is “p12, p11...p2,p1,0,0,0,0”. Right padding is useful when the user wishes to view the TIFF data using a standard TIFF viewer program.

Capture Options Determines how, when and where images are recorded to disk. Three choices are provided: ‘Single Frames’, ‘Series of Frames’ and ‘AVI Video’. Selecting the radio button and then clicking on each option box opens a new dialog providing additional options.

Single Frames Select this option when you wish to record one frame only. Clicking on this button causes the ‘Single Frame Settings’ dialog to open.

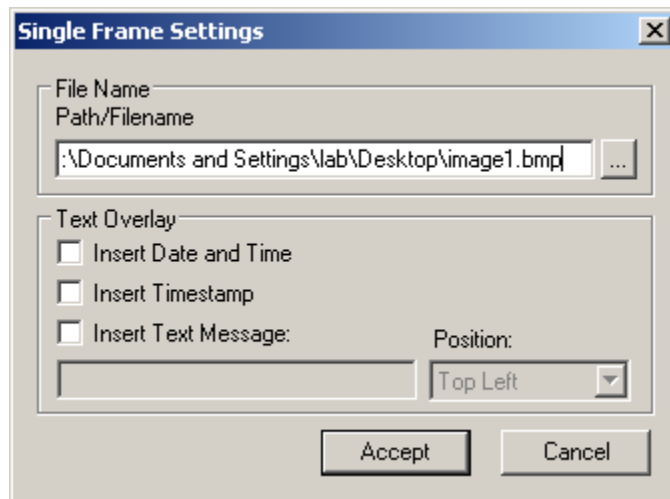

Path/Filename This text field allows you to provide a path and filename for the recorded image file. Clicking on the ‘...’ box will cause a Windows ‘browse’ box to appear. The user can then browse to a folder and enter a file name. The filename extension, .BMP or .JPG, will automatically be added depending on the image format chosen and therefore you do not need to include the filename extension.

Text Overlay Enabling ‘**Insert Date and Time**’ automatically overlays the date and time, received from the PC’s operating system, on each image recorded. Date and time formats are the same as those used on your computer. Enabling ‘**Insert Timestamp**’ automatically overlays an accurate timestamp on each image recorded. The timestamp is a decimal integer value indicating the time, in microseconds, when the card acquired the frame from the attached

camera. Enabling **'Insert Text Message'** allows you to enter a text string to be automatically overlaid on each image recorded. Clicking on **'Position'** causes a pull-down menu to appear which defines the placement position of the date/time/text message within the image. Available options include: Top-Left, Top-Center, Top-Right, Bottom-Left, Bottom-Center and Bottom-Right.

Accept

Clicking on this causes the entries made to the various fields to be accepted and then closes the 'Single Frame Settings' dialog window.

Cancel

Clicking on this causes the entries made to the various fields to be rejected and then closes the 'Single Frame Settings' dialog window.

Series of Frames Select this option when you wish to record multiple frames. Clicking on this button causes the ‘Series of Frames Settings’ dialog to open.

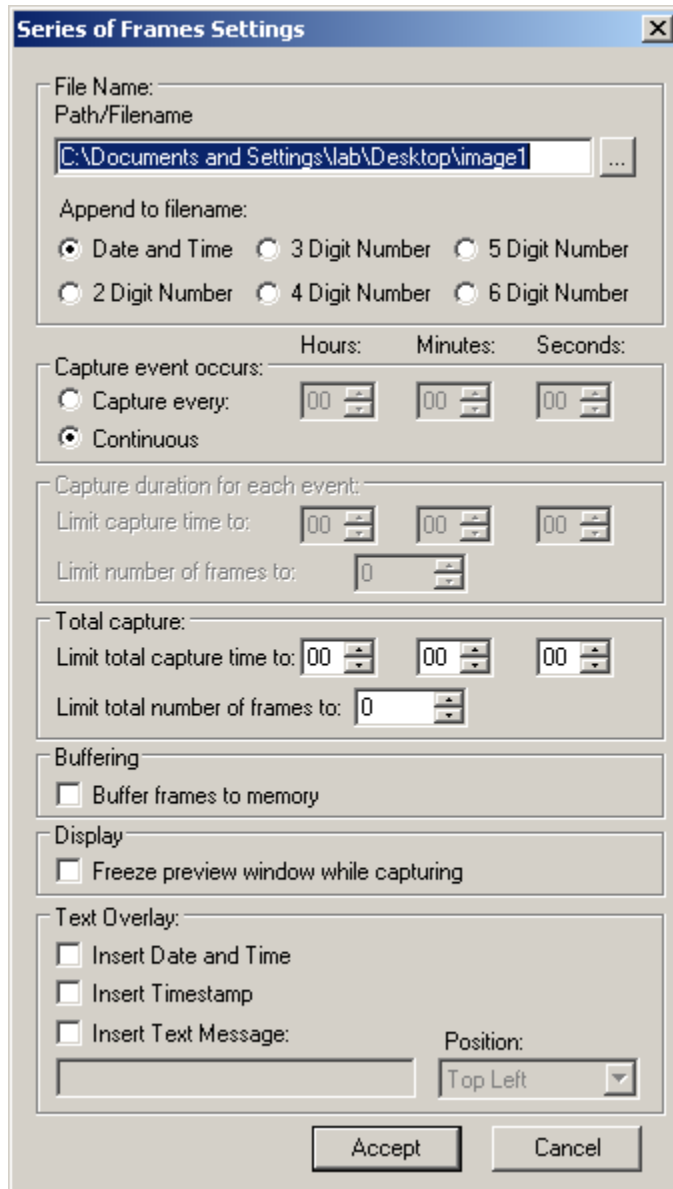

Path/Filename This text field allows you to provide a path to a folder where the recorded image files will be saved to. Clicking on the ‘...’ box will cause a Windows ‘browse’ box to appear. The user can then browse to a folder. The filename will automatically be created based on the choice made in the ‘Append to filename’ option. The filename extension, .BMP or .JPG, will automatically be added depending on the image format chosen.

Append to filename

Allows the user to choose the format of the text filename to be created. Every time a recording file is created, the filename suffix will automatically be updated (for the 'Date and Time' option) or incremented (for the 'N Digit Number' option).

Date and Time

This option will create files named as YYYYMMDDhhmmssnnn where:

- Y - year (4 digits)
- M - month (2 digits)
- D - day (2 digits)
- h - hour (2 digits)
- m - minute (2 digits)
- s - second (2 digits)
- n - millisecond (3 digits)

'N' Digit Number

This option will create numerically named files. The filename starts at 0 and is incremented by one after each frame is captured. If the number of frames captured exceeds the number of digits selected then the filename will continue to increment.

For example:

If '2 Digit Number' is selected then the files will be named as:

'00.bmp', '01.bmp' ... '99.bmp',
'100.bmp', '101.bmp', etc.

If '4 Digit Number' is selected then the files will be named as:

'0000.bmp', '0001.bmp' ... '9999.bmp',
'10000.bmp', '10001.bmp', etc.

Capture event occurs:

Allows you to control how often to start capturing images.

Capture every

Specifies how often, in time, to start capturing images. Use this feature to take snapshots at regular intervals in order to create a time-lapse series of images. This option is mutually exclusive with the 'Continuous' option.

Continuous

Specifies that image capture is free-running.

Capture duration for each event: Allows you to control how much to capture with each capture event specified above. Limits can be specified by either time or number of frames, whichever occurs first.

Limit capture time to Allows you to limit the duration of the recording by the amount of time specified.

Limit number of frames to Allows you to limit the duration of the recording by the number of frames specified.

Total capture: Allows you to control how much to capture over all events specified above. Limits can be specified by either time or number of frames, whichever occurs first.

Limit total capture time to Allows you to limit the duration of the total recording by the amount of time specified.

Limit total number of frames to Allows you to limit the duration of the total recording by the number of frames specified

Examples of how to use Capture timers and counters:

Example #1: To capture 5 frames, every 1.5 hours, over a 12 hour period.

Capture event occurs:

Capture every: 01 Hr 30 Min 00 Sec

Capture duration for each event:

Limit number of frames to: 5

Total capture:

Limit total capture time to: 12 Hr 00 Min 00 Sec

Example #2: To capture 5 minutes worth of images, every 15 minutes and not to exceed a total of 250 images.

Capture event occurs:

Capture every: 00 Hr 15 Min 00 Sec

Capture duration for each event:

Limit capture time to: 00 Hr 05 Min 00 Sec

Total capture:

Limit total number of frames to: 250

Example #3: To capture 10 frames, every 1 hour, over a 6 hour period and not to exceed a total of 300 images.

Capture event occurs:

Capture every: 01 Hr 00 Min 00 Sec

Capture duration for each event:

Limit number of frames to: 10

Total capture:

Limit total capture time to: 06 Hr 00 Min 00 Sec

Limit total number of frames to: 300

Example #4: To capture continuously for a period of 2 hours and not to exceed a total of 100 images.

Capture event occurs:

Continuous

Total capture:

Limit total capture time to: 02 Hr 00 Min 00 Sec

Limit total number of frames to: 100

Buffer frames to memory	When selected will store images in system memory during capturing. When capturing is complete, the images in memory will be flushed to the disk drive. Select this option to improve capture performance (i.e. the number of frames per second stored to disk). If this option is not selected, images will be stored directly to disk and therefore capture performance will be limited by the disk's transfer rate.
Freeze preview window while capturing	When selected will stop the live image in the main window from updating during capture, otherwise the image will remain live. Selecting this option improves capture performance (i.e. the number of frames per second stored to disk).
Text Overlay	Same as in 'Single Frames'.
Accept	Same as in 'Single Frames'.
Cancel	Same as in 'Single Frames'.

NOTE: While capturing is in progress, if the host operating system denies the FrameLink Express application's request to allocate more frame buffers in host memory then the following error message will appear.

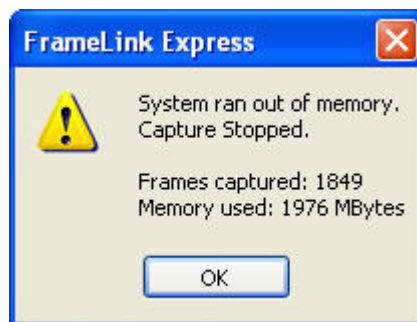

AVI Video

Select this option when you wish to create an AVI movie file. An AVI movie is a series of images assembled into a single AVI file. Clicking on this button causes the 'AVI Video Clip Settings' dialog to open.

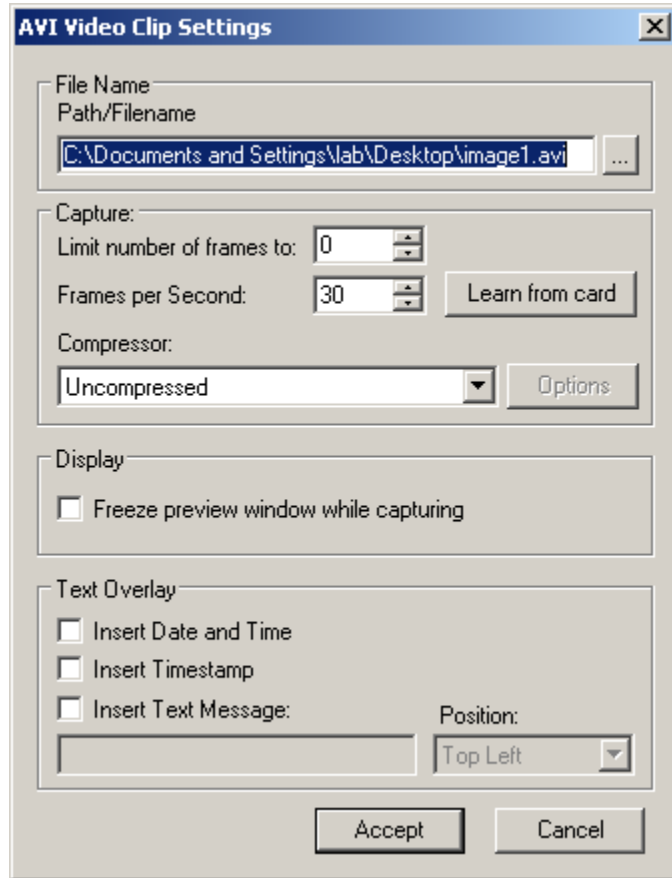

- | | |
|-----------------------------------|--|
| Path/Filename | Same as in 'Single Frames'. |
| Limit number of frames to: | Allows you to limit the duration of the recording by the number of frames specified. |
| Frames per Second: | Limits the frame rate of the recorded movie. |
| Learn from card | Clicking on this button causes the actual frame rate of the attached camera to be read from the card and automatically populated into the 'Frame per Second' field. This option works only if Grabbing is started. |
| Compressor: | Allows you to choose between a variety of compressor implementations and options. This pull-down menu lists several different implementations of AVI compressors. Each has its own set of |

Freeze preview window while capturing	configuration options. Same as in 'Series of Frames'.
Text Overlay	Same as in 'Single Frames'.
Accept	Same as in 'Single Frames'.
Cancel	Same as in 'Single Frames'.

Terminal Dialog

The Terminal dialog allows the user to communicate with the attached camera via the Camera Link's serial interface.

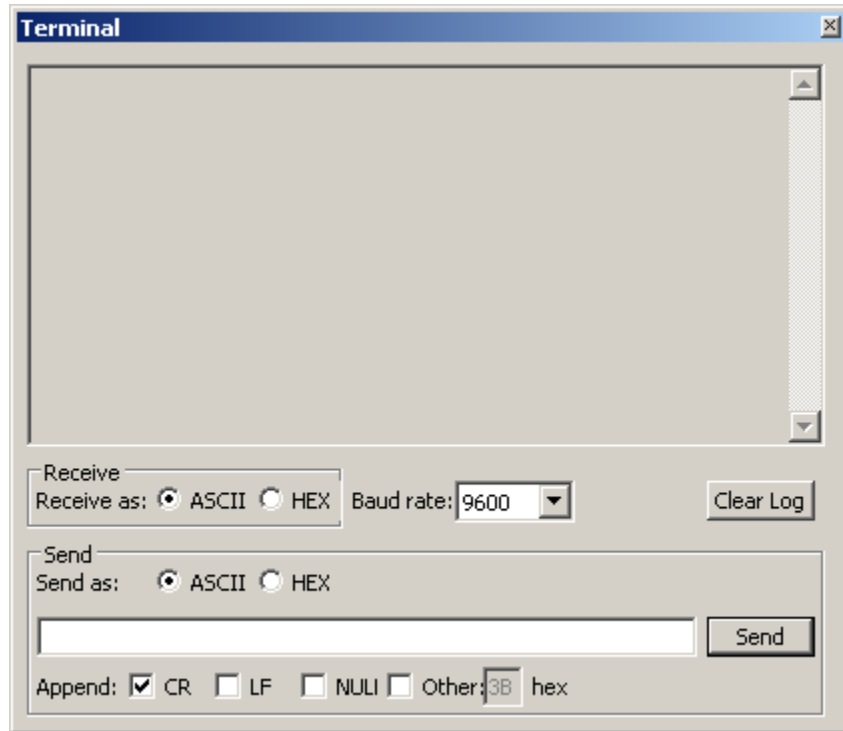

- Receive as** Allows the user to select the format in which he wants received characters to be displayed.
- Baud rate** Specifies the data transfer speed of the CameraLink's serial interface. Clicking on this box causes a pull-down menu to appear. The user can then select the desired baud rate from among the choices presented, ranging from 9600 to 115,200 bits per second. This setting must match the camera's requirements.
- Clear Log** Clears the terminal window of all text.
- Send as** Allows the user to select the format in which he wants transmitted characters to be entered.
- Append** Specifies which control character should be added to the end of the command that the user entered into the Send line.
- Send** Causes the command entered into the Send line to be transmitted to the camera.

Statistics Dialog

The Statistics dialog displays real-time status information about the current camera connection.

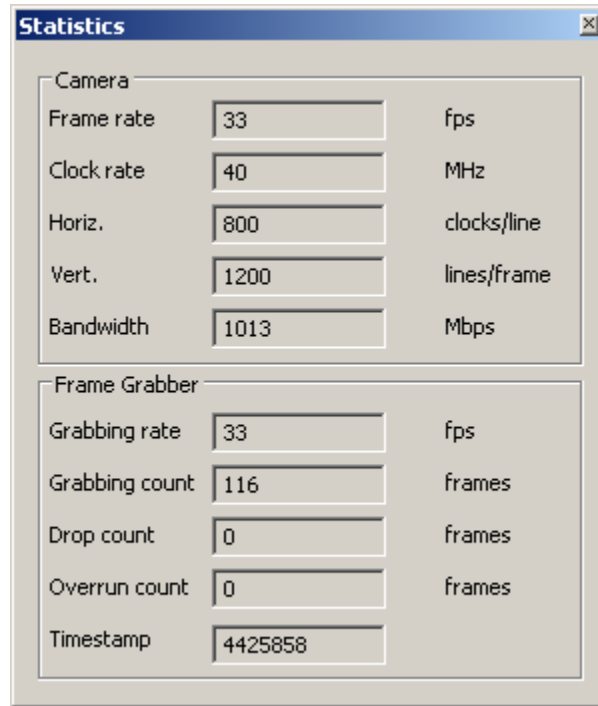

Camera

Displays information related to the attached camera.

Frame rate

Displays the real-time frame rate of the attached camera as measured at the input of the FrameLink Express card.

Clock rate

Displays the real-time Camera Link clock rate of the attached camera as measured at the input of the FrameLink Express card.

Horiz.

Displays the number of clocks/line received from the attached camera as measured at the input of the FrameLink Express card. Note that this value represents the number of pixels/line for single tap mode. For dual tap mode, however, the number of pixels/line is twice the value displayed.

Vert.

Displays the number of lines/frame received from the attached camera as measured at the input of the FrameLink Express card.

Bandwidth

Displays the computed bandwidth required on the PCI Express interface in order to support the attached camera. Bandwidth is a

function of the pixels/line, lines/frame, frame rate, number of taps and bit depth.

Frame grabber Displays information related to the frame grabber.

Grabbing rate Displays the real-time rate at which frames are being transferred from the card into host memory.

Grabbing count Displays a running count of the total number of frames transferred into system memory. This counter is reset when 'grabbing' is stopped.

Drop count Displays a running count of the total number of dropped frames. Dropped frames are defined as frames that were received from the camera but due to a lack of host buffers could not be transferred into host memory. It is the host computer's responsibility to provide the card with pointers into host buffers. If the host computer cannot keep up with the incoming frame rate then the card will drop frames. The primary cause of this is background applications that are competing for the host processors time and preventing it from servicing the FrameLink Express card.

Overrun count Displays a running count of the total number of receiver buffer overruns. Overruns are defined as pixel data that was received from the camera but due to a lack of space, in the card's on-board receiver FIFOs, had to be discarded. Buffer overruns are an indication that the incoming pixel rate exceeds the bandwidth available on the PCI Express interface.

Timestamp Displays a running timestamp counter. Each frame that is received from the camera and transferred into host memory is time stamped. This field shows the timestamp value for the last frame processed.

Hex Pixel Dump Window

The Hex Pixel Dump window displays a two-dimensional table of pixel values, plotting row (Y) vs. column (X), for a bounded region of pixels. The hexadecimal value of each pixel is displayed in each cell. For monochrome formatted images, a single grayscale value is displayed per pixel. For Bayer and RGB formatted images, three values representing R, G and B are displayed per pixel. Additionally, the background color of each cell is grayscale encoded for monochrome images or color encoded for Bayer /RGB images.

Hovering the mouse over a given pixel reveals both the pixel's hexadecimal and integer values. In the monochrome sample image below, with the mouse positioned at location 311, 239 (X, Y), a box is revealed showing that the value of the pixel at that location is 022 in hexadecimal and 34 in integer.

A yellow square, overlaid on the main image window, shows the position of the bounded region. Horizontal and vertical scroll bars allow the user to move the position of the bounded region of pixels anywhere within the entire frame.

Another method of opening the Hex Pixel Dump window is to drag the mouse over the main image window while holding down the left mouse button. This creates the yellow box that defines the pixel dump's bounded region and automatically open the Hex Pixel Dump window.

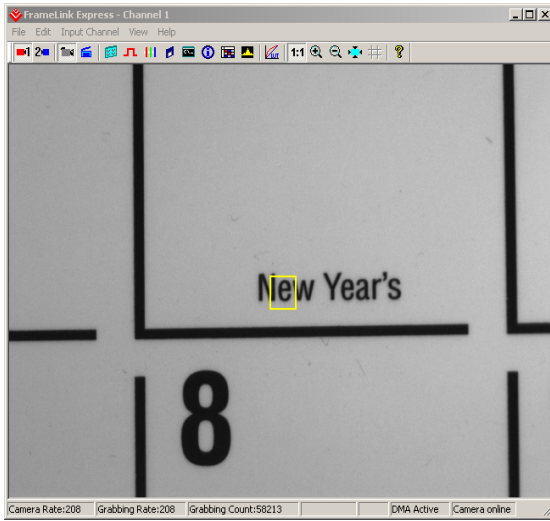

The sample monochrome image.

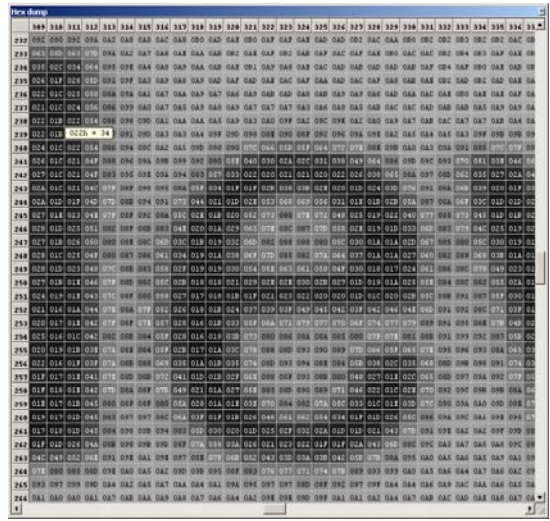

Hex dump for monochrome image.

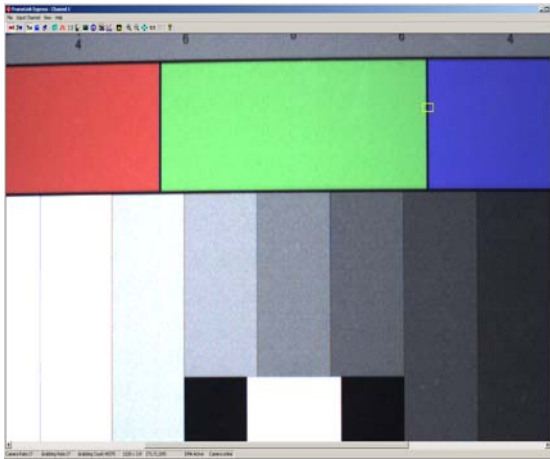

The sample color image.

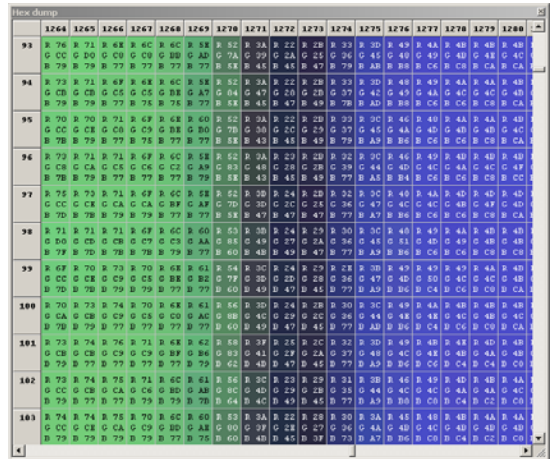

Hex dump for color image.

Histogram Window

The Histogram window displays three graphs: a histogram plot, a horizontal average plot and a vertical average plot.

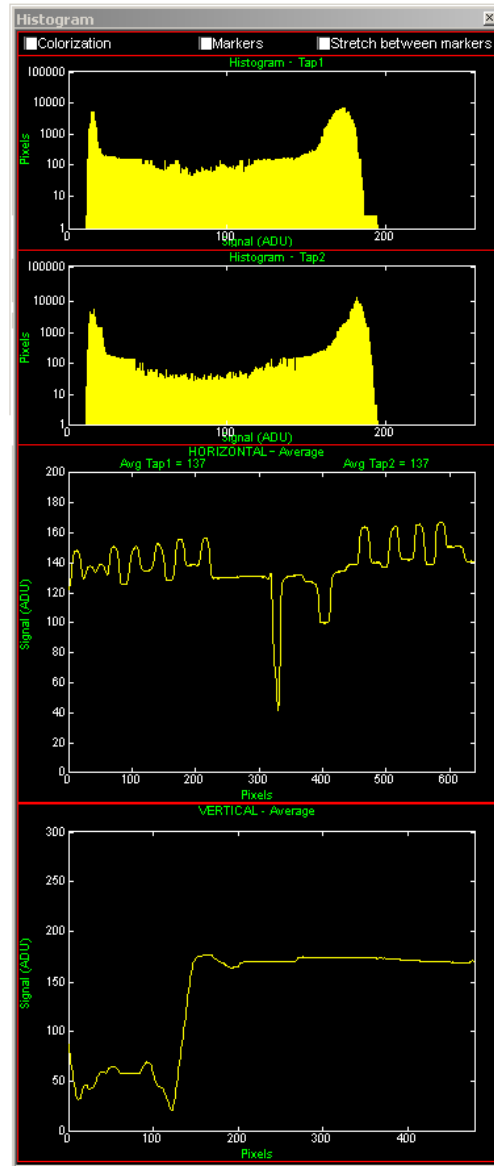

Check Boxes

These features affect the way that the pixel data is altered prior to being displayed in the live preview window. For an illustration of how these features work, see 'Examples of how to use the Histogram' below.

Colorization

Causes the live preview image to be 'colorized'. Colorization results in pixels with no value (i.e. 0 decimal) to be displayed as 'green' and pixels that are saturated (i.e. 4095 decimal in 12 bit mode) to be displayed as 'red'. All other pixels (i.e. from 1 to 4094 decimal in 12 bit mode) are displayed as normal.

Markers

Turns on two vertical markers, 'green' and 'red', that move along the X-axis of the Histogram plot. The 'green' marker can be moved by dragging it with the left mouse. The 'red' marker can be moved by dragging it with the right mouse. The 'green' marker defines a lower limit for the pixel value, while the 'red' marker defines an upper limit for the pixel value. All pixels with a value less than or equal to the lower limit will be converted to 0, while all pixels with a value greater than or equal to the upper limit will be converted to saturated.

For example: in 12 bit mode, the pixel values range from 0 to 4095 decimal. If the lower marker is set to 1000 then all pixels with a value between 0 and 1000 will be converted to 0. If the upper marker is set to 2000 then all pixels with a value between 2000 and 4095 will be converted to 4095.

Stretch between markers

Causes all pixel values lying between the lower marker and the upper marker to be 'stretched', in effect causing contrast enhancement. In the example above, the pixels with values between 1001 and 1999 will be 'stretched' so that they fill the entire range from 1 to 4094. This means that a pixel value of 1001 will be converted to 1 and a pixel value 1999 will be converted to 4094. All other pixels, values 1002 to 1998, will be scaled linearly to fill in the range.

Histogram

Plots the histogram of the current frame displayed in the image window as a function of pixel frequency (Y-axis) vs. pixel value (X-axis). The range of the pixel value, in the X-axis, depends on the bit depth of the camera. For example, the range is 256 for 8 bits, 1024 for 10 bits, etc. The pixel frequency represents the total number of pixels with a given pixel value. Two histogram plots are provided with the upper plot representing CameraLink tap #1 and the lower representing tap #2.

Horizontal Average

Plots the average value of the current frame displayed in the image window as a function of average pixel value (Y-axis) vs. horizontal position (X-axis). The average value for all pixels in a given column of the image is plotted on the Y-axis. The range of the horizontal positions, in the X-axis, depends on the number of columns in the frame.

For example, in the sample illustration, the range of the X-axis is 640 indicating that there are 640 pixels/line in the sample image. In this example, the average of all of the pixels in column number 400 is 100.

A single plot represents both taps. The averages for each tap, however, is listed at the top of the plot.

Vertical Average

Plots the average value of the current frame in the image window as a function of average pixel value (Y-axis) vs. vertical position (X-axis). The average value for all pixels in a given row of the image is plotted on the Y-axis. The range of the vertical positions, in the X-axis, depends on the number of rows in the frame. For example, in the sample illustration, the range of the X-axis is 480 indicating that there are 480 lines/frame in the sample image. In this example, the average of all of the pixels in row number 100 is 50.

Examples of how to use the Histogram

The examples below illustrate the effect that colorization, markers and stretching have on an image. These examples are based on a single tap image with a bit depth of 8 bits.

Example using 'Colorization':

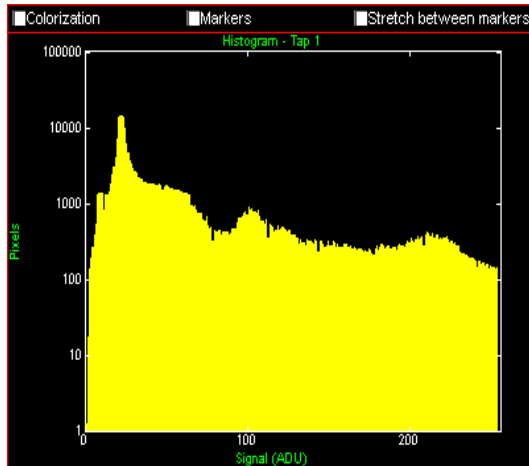

The histogram shows the distribution for the sample image.

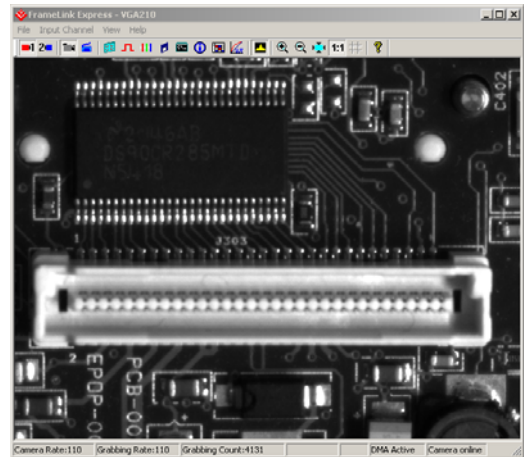

This is the original sample image.

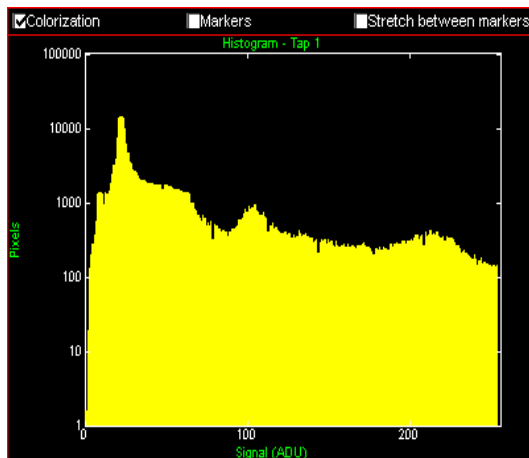

The histogram 'colorization' is turned on.

This causes all pixels with a value of 0 (black) to be converted to green and with a value of 255 (white) to be converted to red.

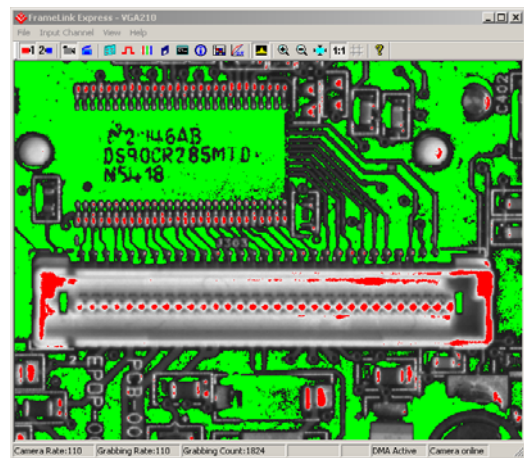

Resultant colorized image.

Example using 'Markers' (for single thresholding):

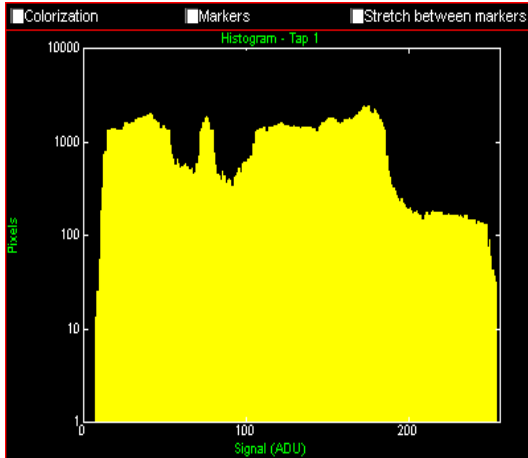

The histogram shows the distribution for the sample image.

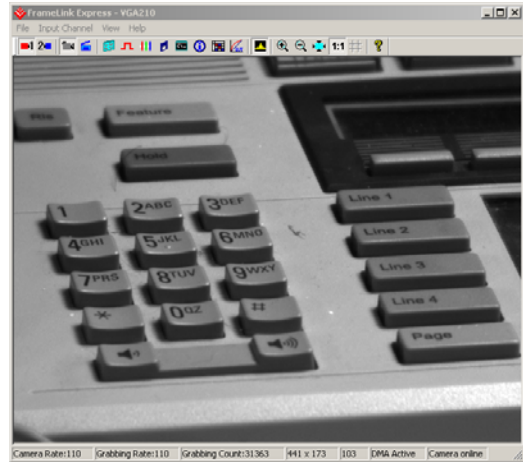

This is the original sample image.

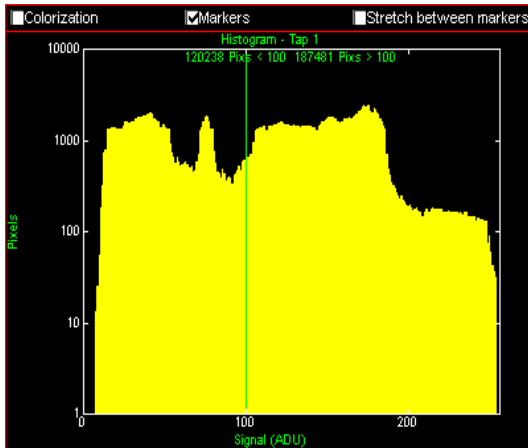

The histogram 'markers' are turned on.

Both the lower limit marker (green) and upper limit marker (red) are set to the same pixel value of 100.

This causes all pixels with a value less than 100 to be converted to black and with a value greater than 100 to be converted to white.

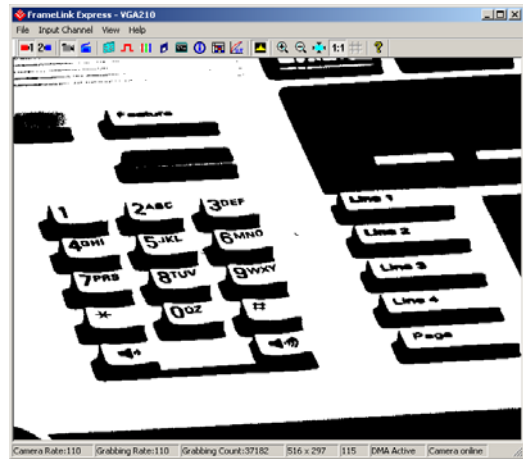

Resultant black & white image with all grayscale removed.

Example using ‘Markers’ (for double thresholding):

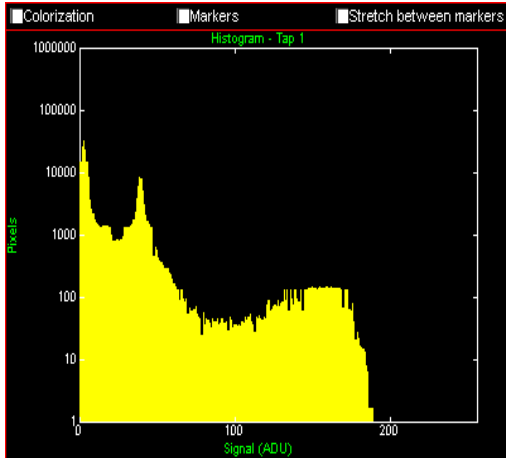

The histogram shows the distribution for the sample image.



This is the original sample image.

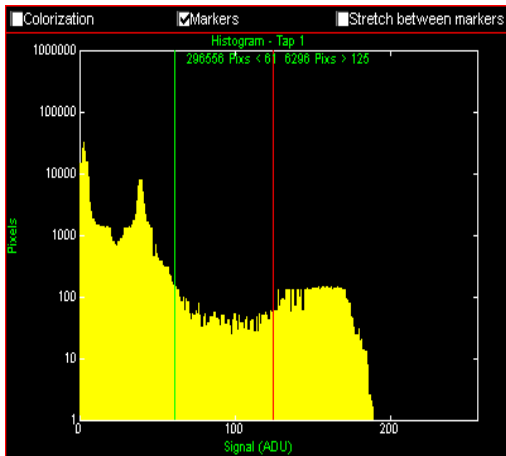

The histogram ‘markers’ are turned on.

The lower limit marker (green) is set to 61 and upper limit marker (red) is set to 125.

This causes all pixels with a value less than 61 to be converted to black and with a value greater than 125 to be converted to white.

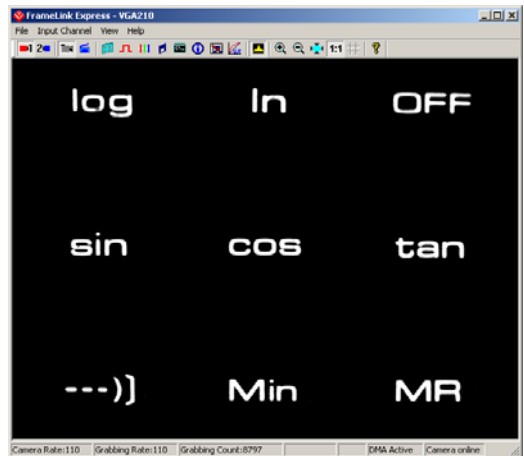

Resultant image.

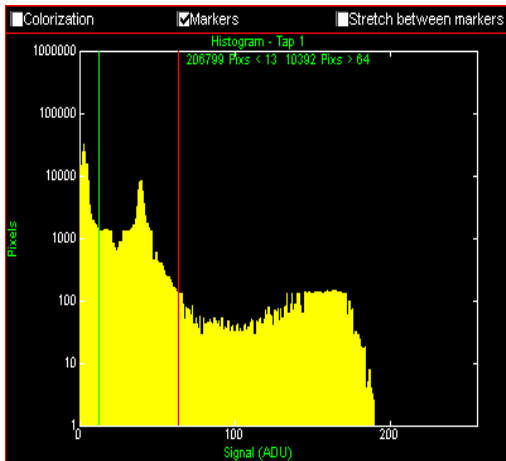

The histogram 'markers' are turned on.

The lower limit marker (green) is set to 13 and upper limit marker (red) is set to 64.

This causes all pixels with a value less than 13 to be converted to black and with a value greater than 64 to be converted to white.

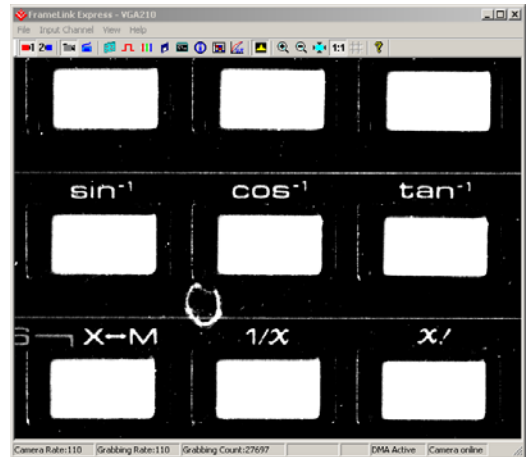

Resultant image.

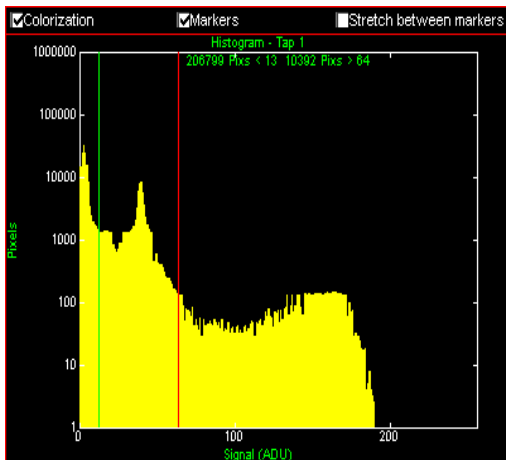

The histogram 'colorization' and 'markers' are turned on.

The lower limit marker (green) is set to 13 and upper limit marker (red) is set to 64.

This causes all pixels with a value less than 13 to be converted to green and with a value greater than 64 to be converted to red.

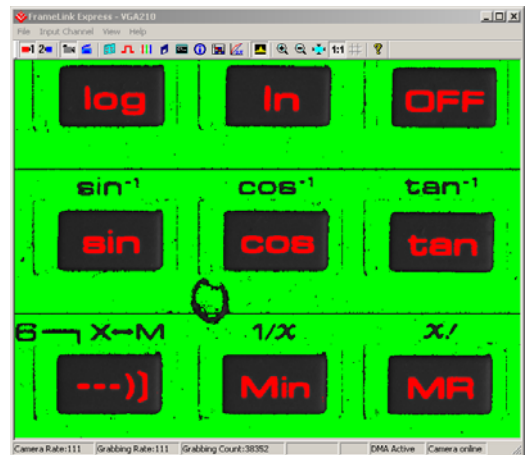

Resultant image.

Example using ‘Stretch between markers’ (for contrast enhancement):

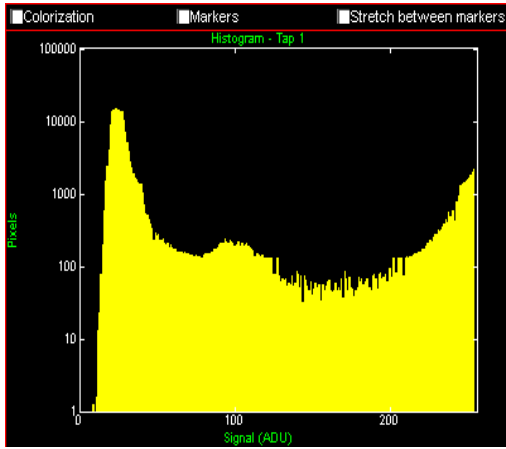

The histogram shows the distribution for the sample image.

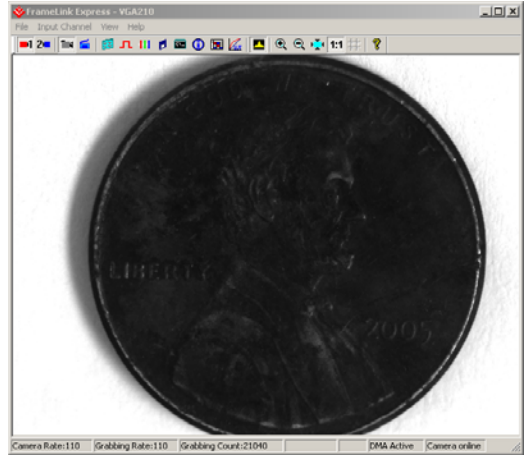

This is the original sample image.

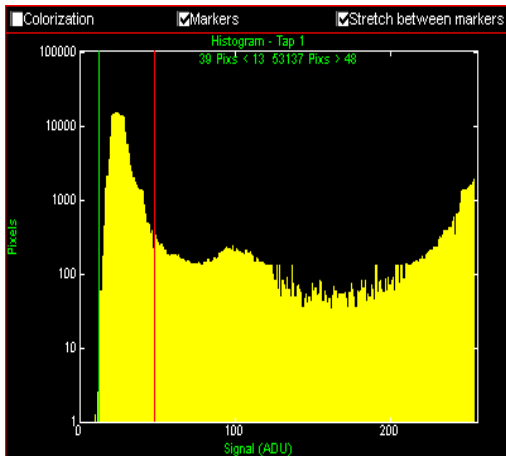

The histogram ‘Markers’ and ‘Stretch’ are turned on.

The lower limit marker (green) is set to 13 and the upper limit marker (red) is set to 48.

This causes all pixels between 13 and 48 to be stretched, all pixels with a value less than 13 to be converted to black and with a value greater than 48 to be converted to white.



Resultant contrast enhanced image.

Lookup Table Dialog

The Lookup Table dialog allows the user to select and enable a lookup table transfer function. The lookup table feature allows the user to modify and transform the original video data into any arbitrary value. Any 12-bit value can be transformed into any other 12-bit value. This is useful for Gamma correction, digital gain/offset, thresh-holding, etc. Refer to Appendix B for details on how to create a Lookup Table.

Note: A Gamma45 lookup table will be loaded by the application program by default.

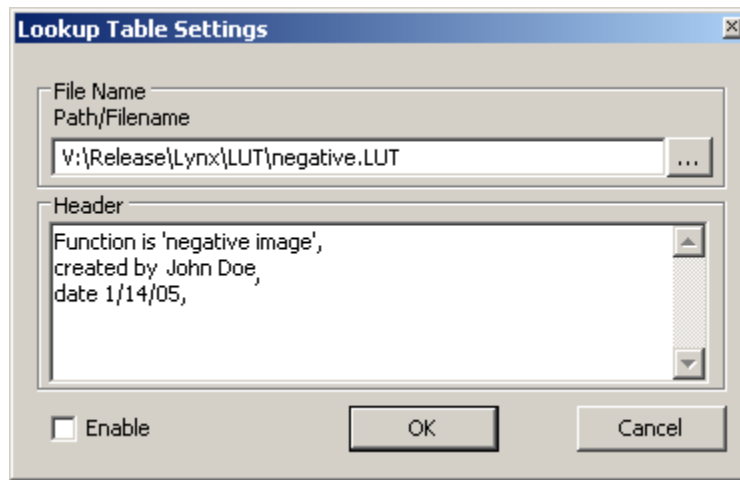

Path/Filename

This text field allows you to provide a path and filename for the lookup table file to be opened. Clicking on the ‘...’ box will cause a Windows ‘browse’ box to appear. The user can then browse to a folder and enter a file name. The filename extension, **.lut**, will automatically be added and therefore you do not need to include the filename extension.

Header

This text window displays the header read from the LUT file. For example, in the negative.lut file illustrated in Appendix C, the header window would list the following:

```
Function is 'negative image',  
created by John Doe,  
date 1/14/05,
```

Enable

Causes lookup table processing to be performed on received images using the selected lookup table file. The resultant image will be displayed in the main image window.

Zoom Menu

The Zoom menu allows the user to select various zooming and scaling functions. The zoom menu can be invoked via the View item on the Menu bar or by right clicking the mouse over the image window..

Zoom in	Ctrl+'+'
Zoom out	Ctrl+'-'
Fit to window	Ctrl+0
25%	Alt+4
50%	Alt+2
✓ 100%	Ctrl+1
200%	Ctrl+2
400%	Ctrl+4

- Zoom in** Causes the displayed image zoom to be increased. The user can hit the 'Ctrl' and '+' keys or the icon from the icon bar as shortcuts.
- Zoom out** Causes the displayed image zoom to be decreased. The user can hit the 'Ctrl' and '-' keys or the icon from the icon bar as shortcuts.
- Fit to window** Causes the displayed image to be scaled to fill the entire image window. The user can change the image window by dragging its sides or corners. Note that the Fit to Window function will maintain the aspect ratio of the original image.
- 25%** Causes the displayed image to be 25% of the original image. This scaling factor will also be applied to the saved image files.
- 50%** Causes the displayed image to be 50% of the original image. This scaling factor will also be applied to the saved image files.
- 100%** Causes the displayed image to be 100% of the original image. This scaling factor will also be applied to the saved image files.
- 200%** Causes the displayed image to be 200% of the original image. This scaling factor will also be applied to the saved image files.
- 400%** Causes the displayed image to be 400% of the original image. This scaling factor will also be applied to the saved image files.

Player Control

Clicking on the 'Play Files' item under the 'File' pull-down menu at the top of the FrameLink Express main window causes two windows to appear: the 'Player Control' and 'Player Dialog' windows. These windows can be moved anywhere around the screen to suit your needs.

The Player Control window is used to select the pre-recorded image or movie files that you wish to view.

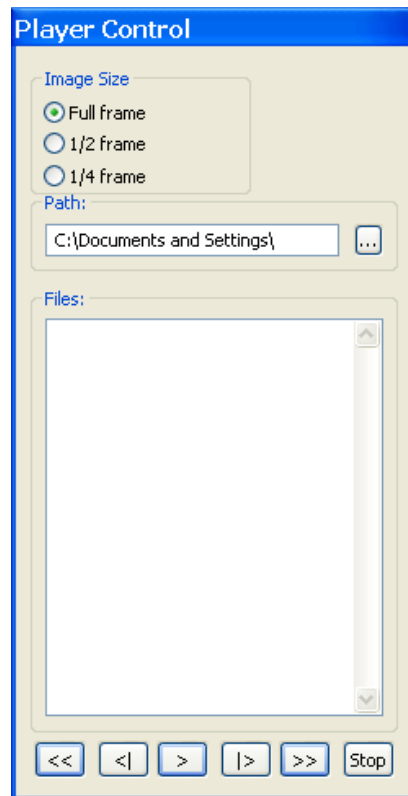

Image Size

Determines the size of the Player Dialog window and the playback image. Changing from one scale to another automatically updates the Player Dialog window and image size.

Path

This text field allows you to enter the name of the folder or directory containing the image or movie files. Clicking on the '...' box will cause a Windows 'browse' box to appear.

Files

This box lists all of the image or movie files that are in the folder selected under 'Path'.

Rewind  Displays the first image in the series.

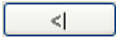
Step Backwards  Displays the previous frame or image. Use this button to back through individual frames of an AVI Movie. Play must be paused for this button to work on AVI Movies.

Play  Begins playing the AVI movie. If you are viewing JPEG or BMP images, clicking this button displays a series of images (one after another) starting from the current file selected in the Player Control dialog.

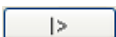
Step Forward  Displays the next frame or image. Use this button to advance through individual frames of an AVI Movie. Play must be paused for this button to work on AVI Movies.

Fast Forward  Displays the last image in the series.

Stop  Halts current playback.

Player Dialog

The Player Dialog window appears when the user selects the 'Play Files' item under the 'File' pull-down menu at the top of the FrameLink Express main window. The Player Dialog window provides the primary area for viewing playback of pre-recorded images or movies. This window can be moved anywhere around the screen to suit your needs.

The size of the window (and image) is determined by the size of the image file selected in the 'Player Control' window and can be scaled using the 'Image Size' option. For example, if the user selects an image file that was produced by a 640x480 resolution camera, then the 'Full frame' window size will be 640x480. In this example, selecting '½ frame' produces a window size of 320x240 and selecting '¼ frame' produces a size of 160x120.

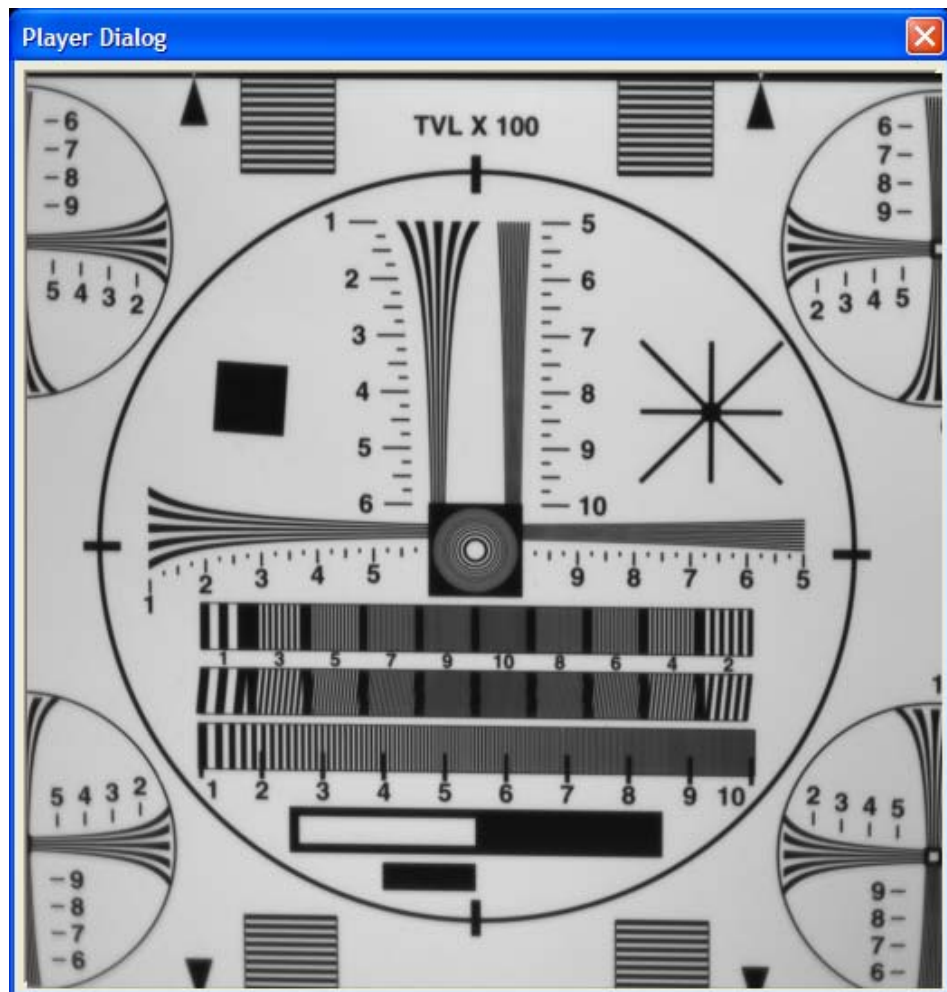

Chapter **5**



Electrical Interfaces

This chapter contains information on the FrameLink Express's connectors.

Camera Link Connector

The CameraLink connectors are shielded, right angle, through hole, 26 position, female, SDR (shrunk delta ribbon) style connectors. Two such connectors are provided on the card. The first connector is used for a Channel #1 Base configuration while the second is used for either a Channel #2 Base or Channel #1 Medium configuration. Note that in the Channel #1 Medium configuration, the second connector's CC[4:1] and SerTC/SerTFG signals are unused.

Pin #	Cable name	Signal name
1	Inner Shield	Inner Shield
2	PAIR11-	CC4-
3	PAIR10+	CC3+
4	PAIR9-	CC2-
5	PAIR8+	CC1+
6	PAIR7+	SerTFG+
7	PAIR6-	SerTC-
8	PAIR5+	X3+
9	PAIR4+	Xclk+
10	PAIR3+	X2+
11	PAIR2+	X1+
12	PAIR1+	X0+
13	Inner Shield	Inner Shield
14	Inner Shield	Inner Shield
15	PAIR11+	CC4+
16	PAIR10-	CC3-
17	PAIR9+	CC2+
18	PAIR8-	CC1-
19	PAIR7-	SerTFG-
20	PAIR6+	SerTC+
21	PAIR5-	X3-
22	PAIR4-	Xclk-
23	PAIR3-	X2-
24	PAIR2-	X1-
25	PAIR1-	X0-
26	Inner Shield	Inner Shield

Table 6 – Camera Link Connector Pin-out

Note that the Camera Link connector pin-out for the frame grabber is 180 degrees rotated from the pin-out for the camera.

ExpressCard Connector

The ExpressCard connector is a surface mount, right angle, 26 position, female connector.

Pin #	Signal name	In/Out	Note
1	GND		
2	USBD-	I/O	not used
3	USBD+	I/O	not used
4	CPUSB#	O	not used
5	reserved		
6	reserved		
7	SMBCLK	I/O	not used
8	SMBDATA	I/O	not used
9	+1.5V		
10	+1.5V		
11	WAKE#	O	3
12	3.3VAUX		5
13	PERST#	I	4
14	+3.3V		
15	+3.3V		
16	CLKREQ#	O	2
17	CPPE#	O	1
18	REFCLK-	I	
19	REFCLK+	I	
20	GND		
21	PERn0	O	
22	PERp0	O	
23	GND		
24	PETn0	I	
25	PETp0	I	
26	GND		

Table 7 – ExpressCard Connector Pin-out

Notes:

- 1 – CPPE# indicates to the host that the card has been inserted.
- 2 – CLKREQ# indicates to the host that the card is requesting that the REFCLK be provided. This is a Power Management function and is not implemented on the FrameLink Express.
- 3 – WAKE# is used to notify the host that it should re-apply power to the card. This is a Power Management function and is not implemented on the FrameLink Express.
- 4 – PERST# is a reset signal driven by the host to reset the card.
- 5 – 3.3VAUX is used to power the WAKE# circuitry. This is a Power Management function and is not implemented on the FrameLink Express.

PCIe x1 Connector

The PCIe x1 connector is a vertical, edge-finger, two-sided, 36 position connector. Side B is on the primary (component) side and Side A is on the secondary (solder) side. Both pins A1 and B1 are closet to the I/O bracket.

Side B				Side A			
Pin #	Signal name	In/Out	Note	Pin #	Signal name	In/Out	Note
B1	+12V			A1	PRSNT1#	O	5
B2	+12V			A2	+12V		
B3	+12V			A3	+12V		
B4	GND			A4	GND		
B5	SMBCLK	I	1	A5	JTAG_TCK		2
B6	SMBDAT	I/O	1	A6	JTAG_TDI		2
B7	GND			A7	JTAG_TDO		2
B8	+3.3V			A8	JTAG_TMS		2
B9	JTAG_TRST#	I	2	A9	+3.3V		
B10	3.3Vaux		3	A10	+3.3V		
B11	WAKE#	O	2	A11	PERST#	I	6
B12	reserved			A12	GND		
B13	GND			A13	REFCLK+	I	
B14	PETp0	I	7	A14	REFCLK-	I	
B15	PETn0	I	7	A15	GND		
B16	GND			A16	PERp0	O	7
B17	PRSNT2#	O	5	A17	PERn0	O	7
B18	GND			A18	GND		

Table 8 – PCIe x1 Connector Pin-out

Notes:

- 1 – The SMB Bus is not implemented on the FrameLink PCIe card.
- 2 – The JTAG interface is not implemented on the FrameLink PCIe card.
- 3 – 3.3Vaux is used to power the WAKE# circuitry. This is a Power Management function and is not implemented on the FrameLink PCIe card.
- 4 – WAKE# is used to notify the host that it should re-apply power to the card. This is a Power Management function and is not implemented on the FrameLink PCIe card.
- 5 – PRSNT1# is tied to PRSNT2# and is used by the host to sense card insertion/removal.
- 6 – PERST# is a reset signal driven by the host to reset the card.
- 7 – Direction for transmit and receive signals are relative to the host.

Chapter 6

Specifications

Video Source	Camera Link interface (Base configuration using a single 26 pin connector or Medium configuration using two 26 pin connectors). Base modes supported: 1x8, 2x8, 3x8, 1x10, 2x10, 1x12, 2x12, 1x14, 1x16 and RGB24 Medium modes supported: 4x8, 3x10, 4x10, 3x12, 4x12, RGB30 and RGB36. Camera Link clock rates from 20 MHz to 85 MHz. RS232 Serial interface (per channel) for configuring & monitoring camera. Four discrete camera control LVDS differential outputs (per channel) to camera (CC1 to CC4).
Physical Dimensions	Low-profile PCIe x1 : 168mm(6.6in) x 64mm(2.5in). ExpressCard/54 : 108mm(4.3in) x 54mm(2.1in) x 18mm(.7in). ExpressCard/34 : 108mm(4.3in) x 34mm(1.3in) x 18mm(.7in).
Weight	Low-profile PCIe x1 : 58.0 grams (2.05 oz) ExpressCard/54 : 53.6 grams (1.91 oz) ExpressCard/34 : 35.9 grams (1.27 oz)
Electrical Characteristics	Operating voltage: 3.3V +/- 5% Operating current: 500mA
Operating Environment	Operating temperature: 0°C to 65°C Relative humidity: 90% non-condensing
Regulatory	FCC 15 part B, CE, RoHS

Appendix

A

Serial Communications

The FrameLink Express provides a Camera Link compliant serial communications channel. This is an ASYNC interface operating at a user selectable BAUD rate (set via the Camera Parameters dialog), with 1 start bit, 8 data bits, 1 stop bit, no parity and no handshake.

Clseripx.dll

Any standard camera configuration software can access this serial interface by using the FrameLink Express's clseripx.dll file (located in the c:/WINDOWS/system32 folder for WinXP or c:/WINNT/system32 folder for Win2000). The clseripx.dll is fully compliant with v1.2 of the Camera Link specification.

COM port emulation

Alternatively, if the camera configuration software does not provide an interface to the Camera Link clser***.dll but only supports standard COM ports, then the user can invoke our VceComEX.exe COM port emulator. This software will emulate a PC COM port allowing any terminal emulator or camera configuration tool to access the FrameLink Express serial interface.

To create a virtual COM port, simply run the VceComEX.exe program. Then select the port number from the pull-down list and click on 'Create Port'. You can now begin using the virtual COM port in you terminal or camera configuration software. **NOTE: You must not exit the VceComEX program while it is in use.** When you are done using the COM port, then click on 'Delete Port' and 'Exit'.

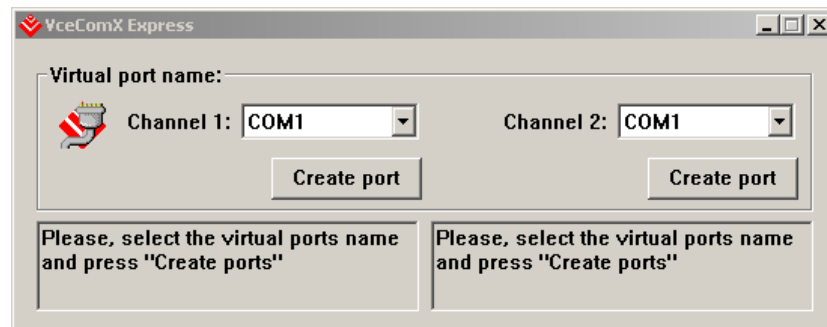

Appendix

B

Creating Look Up Tables

This appendix provides a reference on how to create a lookup table using both an ASCII editor and an Excel spreadsheet.

Overview

The Lookup Table file can be created using any standard ASCII text editor or by using Microsoft Excel. Additionally, any spreadsheet or mathematical program capable of generating a comma delimited file can be used.

Using an ASCII text editor

A custom LUT (lookup table) can be prepared using any ASCII text editor. Alternatively, any spreadsheet program (i.e. Microsoft Excel) can be used by converting the spreadsheet into a comma delimited (.csv) file. In either case, the file must be renamed to include the .lut extension. The .lut file has two main sections: a header and a table. The 'header' section is a free text area of up to 256 ASCII characters. Each line of the header section must be terminated in a comma. The 'table' section of the file contains an array of 4096 lines with each line containing an input value followed by a comma and an output value. The input values represent incoming pixels and the output values represent what each incoming pixel should be converted into as an output pixel.

LUT Format

```
-- Look Up Table input file example,  
-- lines beginning with two dashes are comments,  
-- and are ignored by parser,  
:Header,  
Function is 'negative image',  
created by John Doe,  
date 1/14/05,  
:Table,  
--input output,  
0,4095  
1,4094  
2,4093  
3,4092  
4,4091  
:  
4095,0
```

Using Microsoft Excel

The .LUT file can be created in Excel as follows:

- 1 - create the spreadsheet as shown below (note that 4096 rows are required in the table).
- 2 - add the necessary equations into the output cells to generate the transfer function required.
- 3 - save the file as a .csv (comma delimited format).
- 4 - rename the .csv file to an extension of .lut.

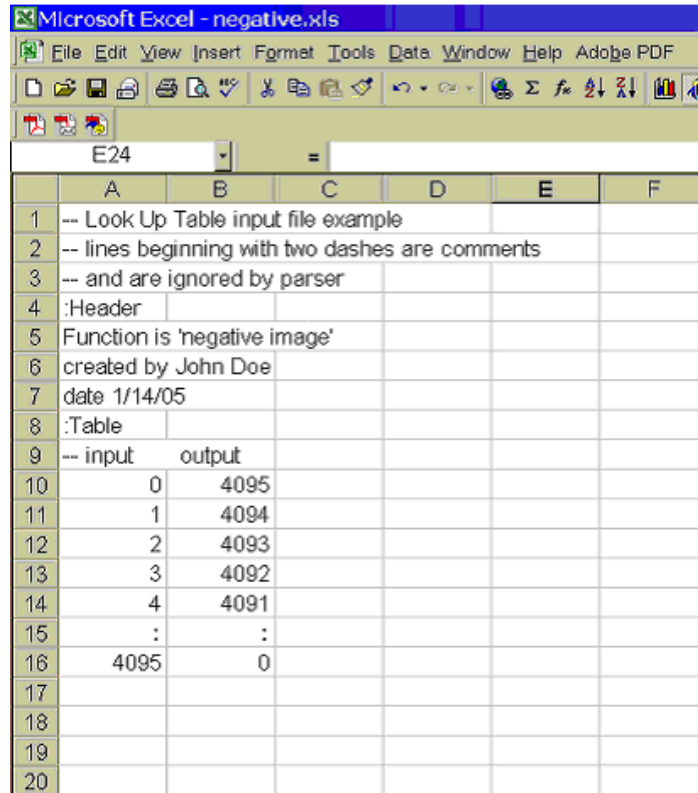

	A	B	C	D	E	F
1	-- Look Up Table input file example					
2	-- lines beginning with two dashes are comments					
3	-- and are ignored by parser					
4	:Header					
5	Function is 'negative image'					
6	created by John Doe					
7	date 1/14/05					
8	:Table					
9	-- input	output				
10	0	4095				
11	1	4094				
12	2	4093				
13	3	4092				
14	4	4091				
15	:	:				
16	4095	0				
17						
18						
19						
20						