

Megapixel USB2.0 CMO
CAMERA

Data Sheet

SMX-150M USB2.0 Camera

SMX-150M USB2.0 Camera Data Sheet

Revision 3.0

Copyright © 2001-2010 Sumix Corporation

4005 Avenida de la Plata, Suite 201

Oceanside, CA, 92056

Tel.: (877)233-3385; Fax: (508) 300 5526

Email: camera@sumix.com

www.sumix.com

The information in this document is subject to change without notice. The product described in this document is furnished under a license and be used or copied only in accordance with the terms of such license.

Contents

Contents	3
Introduction	5
Key Features	5
Specifications	6
Output video and camera control characteristics	6
Imaging chip characteristics	6
Camera electrical characteristics	7
Camera interface characteristics	7
System requirements	7
Camera Mechanicals	8
Camera physical characteristics	8
External connector pinout	9
General Sensor Specifications	9
Spectral response curve	9
Photo-voltaic response curve	10
Features of the IBIS5-AE-1300 sensor	11
Pixel architecture	12
Cover glass	12
Multiple slope integration	13
Double slope integration	13
Non-linear and linear conversion mode - "gamma" correction	14
SMX-150M Software Package	15
Drivers	16
System requirements	16
API function categories	16
Camera application controls	17
Third-Party IDE/Software Compatibility	17
Assistance and Help	18
Camera Customization	18
Camera Accessories	19
Sample Images	20
Figures	23

Introduction

SMX-150M USB2.0 Camera is a high speed 1.3 (1280 x 1024) megapixel CMOS camera with USB2.0 interface. It is designed for capturing, streaming and storing high quality digital images and can be used for industrial and scientific imaging applications.

For special applications, the SMX-150M camera is available in three modifications:

- The SMX-150M-E camera with enhanced NIR response (IBIS5-AE-1300 sensor)
- The SMX-150M-W camera with a protection glass lid removed (IBIS5-A-1300 sensor)
- The SMX-150M-E-W camera with enhanced NIR response and a protection glass lid removed (IBIS5-AE-1300 sensor)

The camera has a 2/3" optical sensor and features frame rate of 27.5 fps (40 MHz) at the 1280 x 1024 resolution. Rolling and Global shutters, External Trigger output mode are available.

Capturing of initial live streaming video images and still images is provided via USB 2.0 digital interface - no additional frame grabber is needed.

The camera is provided with the Software Package, all needed drivers and API library, which allows quick integrating of the camera functions into user applications.

Key Features

- High speed: 27.5 fps at full 1280 x 1024 resolution
- USB2.0 interface
- 1280 x 1024 active imaging pixels
- Global and Rolling shutters
- Low image noise
- Small size
- C-Mount
- No external power supply required
- External trigger output mode
- Video and snapshot operations
- Multi-slope integration (Global shutter)
- Double-slope integration (Rolling shutter)
- Selectable pixel data: 8 bit or 10 bit
- Complete SDK

Specifications

Table 1-1 Camera Specifications

Output video and camera control characteristics	
Maximum resolutions of output window:	1280 x 1024, full resolution mode 640 x 512, decimated by 2 mode
Frame rate at resolution (40MHz)*:	27.5 fps at 1280 x 1024, full resolution 45 fps at 1024 x 768 76 fps at 768 x 576 106 fps at 640 x 480 182 fps at 400 x 400 494 fps at 220 x 220
Output bits per pixel:	Selectable, 8 bits or 10 bits
Lookup table:	Downloadable for user selected 8 bits mode: converts 10 bits of imaging chip's ADC to 8 bits of output
Pixel rates:	3.33 MHz, 6.66 MHz, 8 MHz, 10 MHz, 12 MHz, 13.33 MHz, 16 MHz, 20 MHz, 24 MHz, 32 MHz, 40 MHz
Exposure range (at resolution 1280x1024), ms:	min: 0.04 (at 40 MHz); max: 437.95 (at 3.33 MHz)
Pixel gain control:	Programmable (Hardware): 17 gain levels from 0 to 12.4;
Output window modes:	View port (from 1280 x 1024 to 8 x 8 with 2 pixels/line step positioning); Frame Decimation (1:1, 1:2); Horizontal mirroring; Vertical flipping
Gamma, brightness and contrast control:	Programmable with lookup table, hardware gamma correction
* Listed frame rate values at the defined resolutions are not the maximal possible. Increasing of frame rate can be done by reducing the current Exposure value (the lower Exposure, the higher frame rate), hiding the active video window from the display, running the camera with a fast speed computer, etc.	
Imaging chip characteristics	
Type:	Monochrome 1.3 megapixel CMOS sensor with an optical format of 2/3"; manufactured by Cypress (FillFactory)
Pixel size:	6.7 μm x 6.7 μm
Image array size:	8.6 mm x 6.9 mm

Table 1-1 Camera Specifications

Shutter:	Rolling shutter; Global Shutter - triggered synchronous shutter with integration and readout separate in time
Scanning mode:	Progressive
ADC resolution:	10 bits
Pixel architecture:	4-transistor active pixel sensor; Allows for both rolling and synchronous (snapshot) shutter
Sensitivity	3.29 V/lux.s Visible band only (180 lux = 1 W/m ²); 8.46 V/lux.s Visible + NIR (70 lux = 1 W/m ²)
Dynamic range	Optical, 64dB (1600:1) in single slope operation and 80...100dB in multiple slope operation
Camera electrical characteristics	
Supply voltage:	5 V supplied by USB2.0 interface
Supply current:	360 mA (at 5.0 V)
Maximum power consumption:	1.8 W
Camera interface characteristics	
Interface Type:	USB2.0, 480Mbps
Connector Type:	USB mini-B, 5 pin
System requirements	
Operating System:	Windows XP SP1+/2003/Vista/2008/7 recommended: Windows 7 or XP 1+
Processor:	Intel P4 or higher recommended: Intel Core 2 Duo
RAM:	256 MB for XP (512 MB for 2008/Vista) recommended: 512 MB (1024 MB for W7)
Performance	minimum: 300 Mflops recommended: 400 Mflops or higher
Hard Disk Space:	About 15 MB for installation plus additional space for captured images
Video:	8 MB memory, recommended GeForce 4xxx/ Radeon 9xxx or higher

Table 1-1 Camera Specifications

Hardware Interface:	USB 2.0 Host Controller: recommended Intel integrated Host Controller (VIA-based USB Controller not recommended) USB 3.0 Host Controller is also supported at least one USB 2.0 port for connection
Camera physical characteristics	
Operating temperature:	0 to +50°C
Lens mount type:	C-mount
Weight (without lens):	108 g
Dimensions (W x L x H):	54.2 x 54.2 x 32.6 mm
Camera housing material:	Duralumin

Camera Mechanicals

**Figure 1-1** Camera drawing



Figure 1-2 SMX-150M camera outlook

External connector pinout

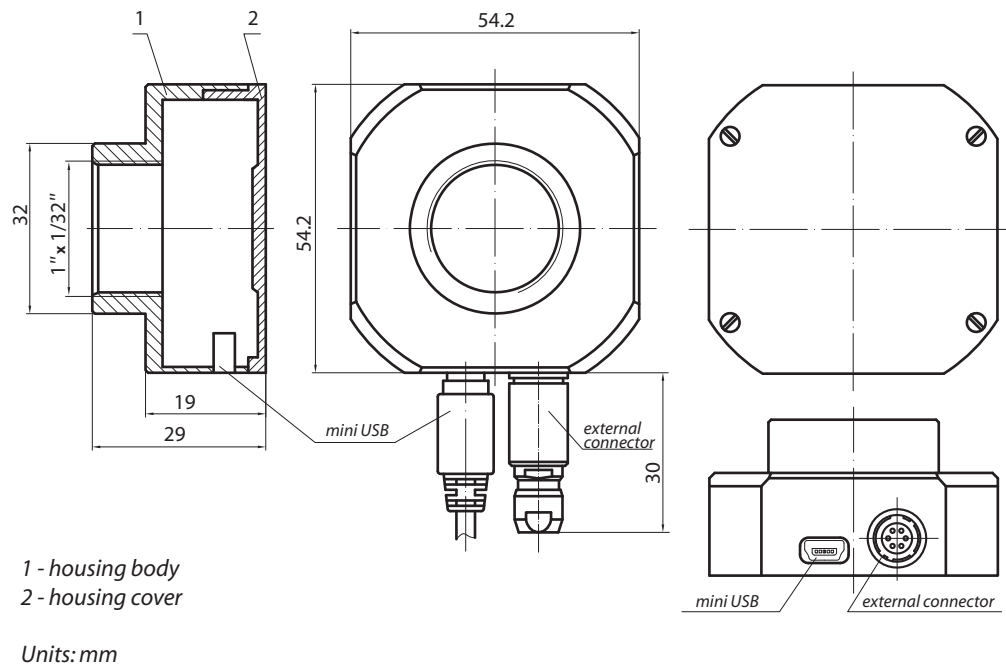
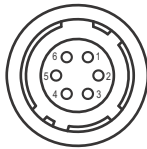

Figure 1-3 Pinout

1. External trigger input (Positive)
2. Delayed synchronous shutter start output (Positive)
3. User programmed output
4. External trigger input (Negative)
5. Synchronous shutter start output (Positive)
6. Common (ground)

General Sensor Specifications

SMX-150M USB2.0 Cameras use IBIS5A-1300 and IBIS5-AE-1300 sensors manufactured by FillFactory (Cypress).

The IBIS5A-1300 sensor has a 10 bit flash analog digital converter running nominally at 40 Msamples/s. The ADC is electrically separated from the image sensor.

The IBIS5-AE-1300 is a special version of the IBIS5-A-1300 with enhanced NIR response.

Spectral response curve

The curve is measured directly on the pixels. It includes effects of non-sensitive areas in the pixel, e.g. interconnection lines.

The sensor is light sensitive between 400 and 1000 nm. The peak QE * FF is approximately 30% between 500 and 700 nm. In view of a fill factor of 50%, the QE is thus larger than 60% between 500 and 700 nm.

[Figure 1-4](#) shows the spectral response characteristics of both IBIS5-A-1300 and IBIS5-AE-1300 sensors.

The IBIS5-AE-1300 has a superior response in the NIR (Near Infra Red) range (700-900 nm).

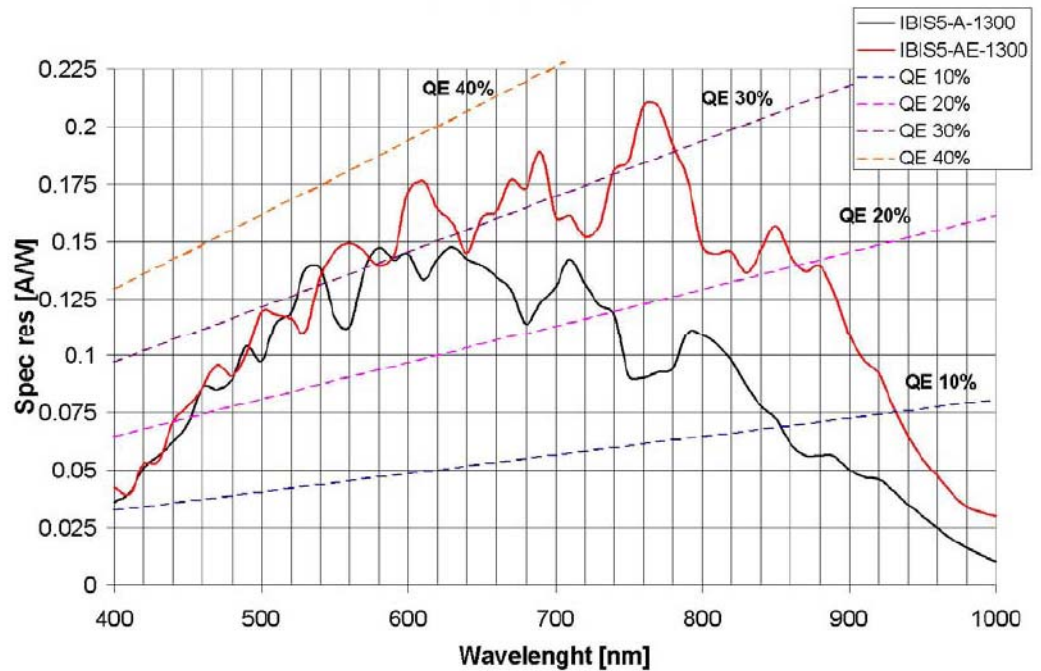

Figure 1-4 Spectral response characteristics

Photo-voltaic response curve

[Figure 1-5](#) shows the pixel response curve in linear response mode. This curve is the relation between the electrons detected in the pixel and the output signal. The voltage to electrons conversion gain of the pixel is 17.6 $\mu\text{V}/\text{electron}$.

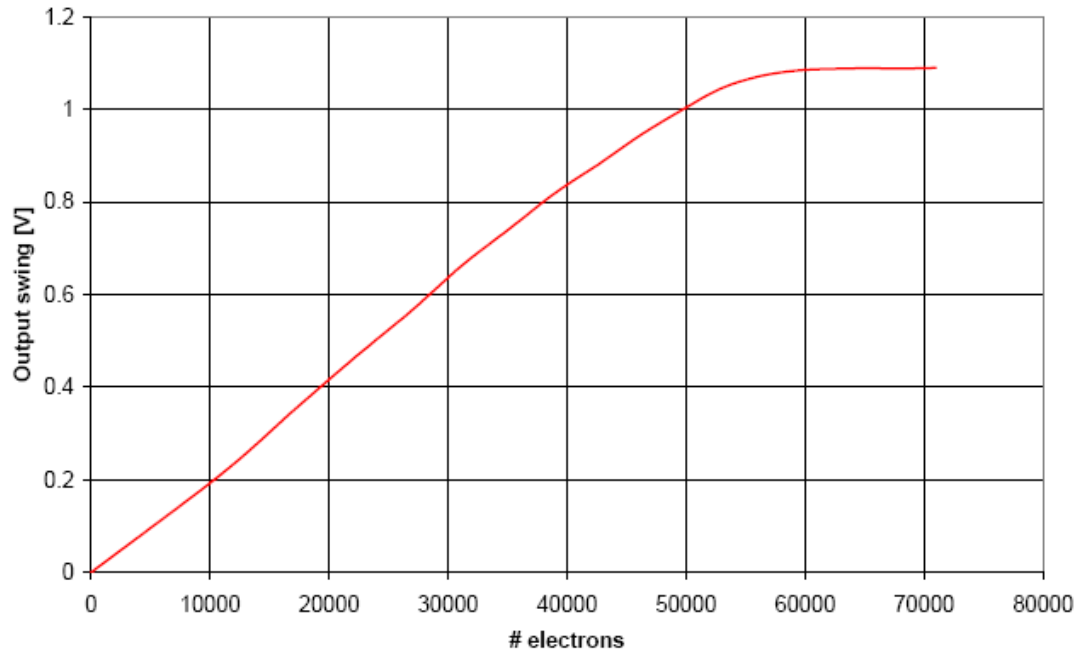

Figure 1-5 Photo-voltaic response curve

Features of the IBIS5-AE-1300 sensor

The IBIS5-AE-1300 sensor is processed on a thicker epitaxial Si layer, featuring a superb sensitivity in the NIR (Near Infra Red) wavelengths (700 - 900 nm). The spectral response curves of the two IBIS5-A-1300 image sensors are shown in [Figure 1-4](#). As many machine vision applications use light sources in the NIR, the IBIS5-AE-1300 sensor has a significant sensitivity advantage in the NIR.

A drawback of the thicker epitaxial-layer is a slight performance decrease in MTF (Modular Transfer Function or electrical pixel-to-pixel cross talk) as indicated in the table below.

Table 1-2 MTF comparison

Direction	Wavelength	IBIS5-A-1300	IBIS5-AE-1300
Horizontal	600	0.58	0.37
Horizontal	700		0.18
Horizontal	800		0.16
Horizontal	900		0.07
Vertical	600	0.53	0.26
Vertical	700		0.16
Vertical	800		0.13

Table 1-2 MTF comparison

Direction	Wavelength	IBIS5-A-1300	IBIS5-AE-1300
Vertical	900		0.11

The resulting image sharpness is hardly affected by this decreased MTF value.

Both IBIS5-A-1300 and IBIS5-AE-1300 sensors are fully pin compatible and have an identical timing and biasing.

Pixel architecture

The pixel architecture used in the IBIS5A-1300 sensor is 4-transistor pixel as shown in [Figure 1-6](#).

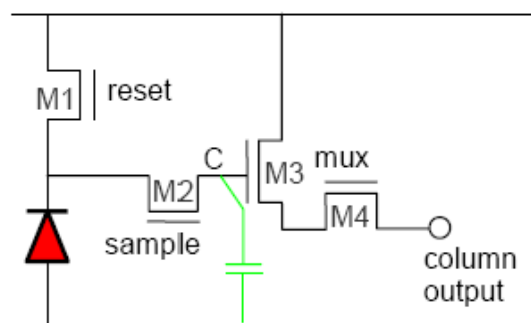

Figure 1-6 Architecture of the 4T-pixel

Cover glass

D263 glass is used as protection glass lid on top of the IBIS5A-1300 monochrome sensors. [Figure 1-7](#) shows the transmission characteristics of the D263 glass.

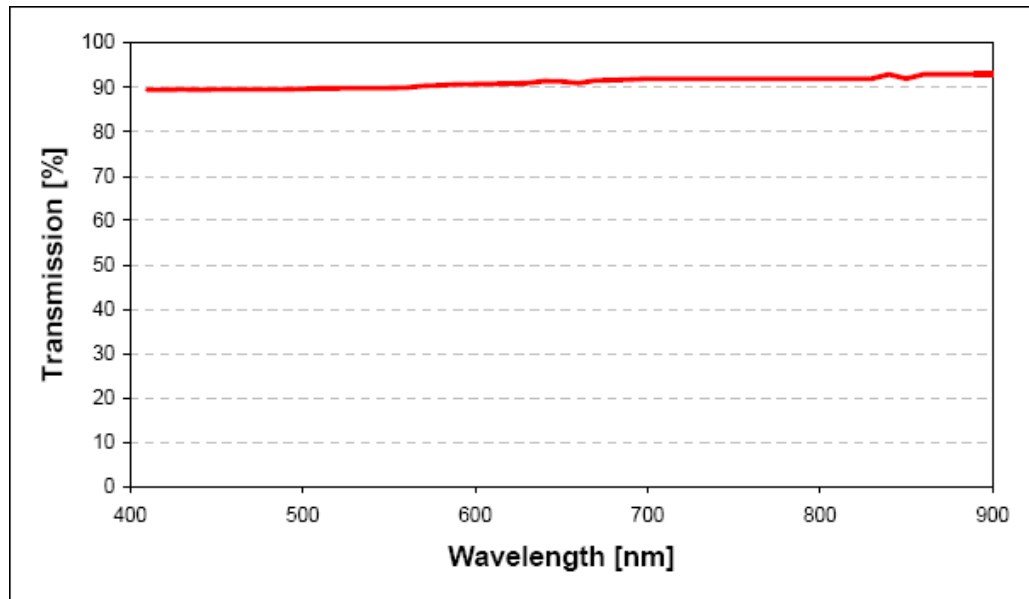

Figure 1-7 Transmission characteristics of the D263 glass used as protective cover for the IBIS5A-1300 sensors (monochrome)

Multiple slope integration

The Exposure modes are provided to extend the dynamic range by integrating long and short frame exposure. Multiple Slope Exposure is done for Global shutter. Double and Single Slope modes are done for Rolling shutter.

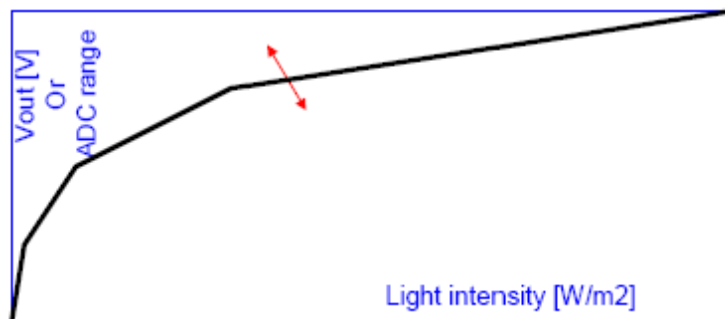

Figure 1-8 Multiple slope response

Double slope integration

Dual slope is a method to extend the dynamic range of a normally linear-transfer imager, by combining the images taken with a long integration time (dark areas of a scene) and a short integration time (bright areas of a scene) into one image. The resulting electro-optical transfer curve is bi-linear. Multiple slope is an extension of it, resulting in a multi-linear transfer curve with multiple knee points.

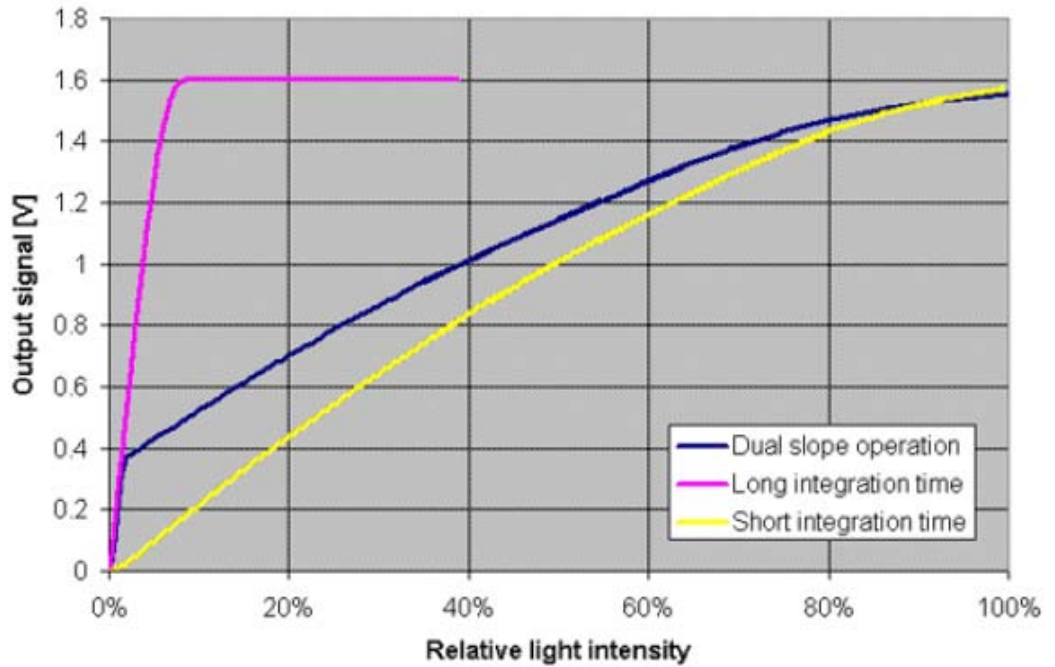

Figure 1-9 Double slope response

Non-linear and linear conversion mode - "gamma" correction

The non-linear (exponential) ADC conversion is intended for gamma-correction of the images. It increases contrast in dark areas and reduces contrast in bright areas.

For the SMX-150M cameras the hardware gamma correction is integrated.

[Figure 1-10](#) shows the ADC transfer characteristics.

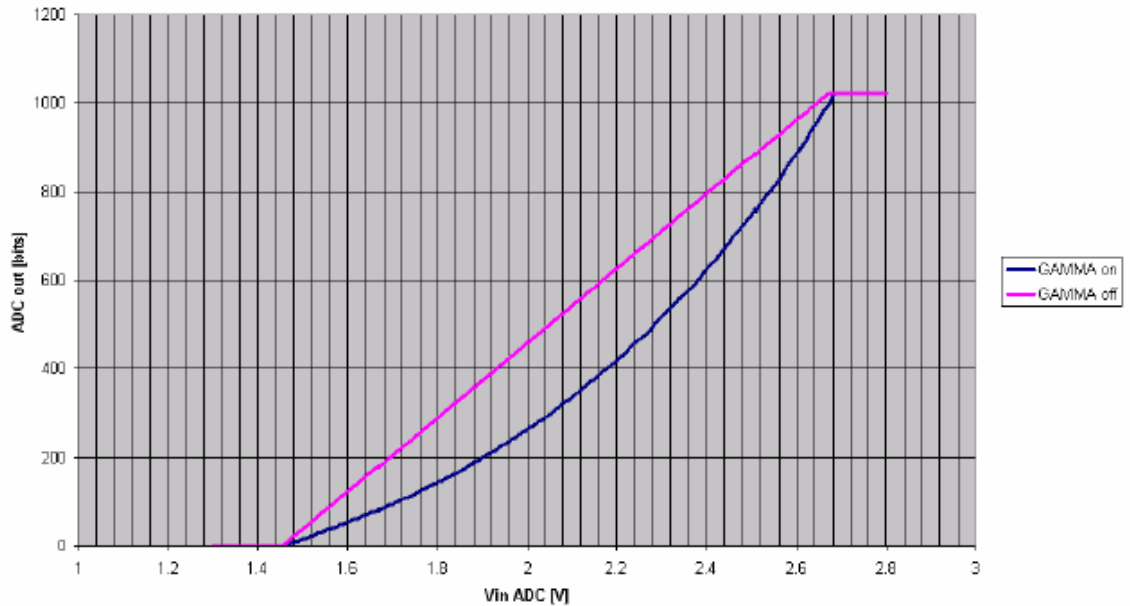

Figure 1-10 Linear and non-linear ADC conversion characteristics

SMX-150M Software Package

The **SMX-150M USB2.0 Cameras** go with the camera software package.

The camera software package includes:

- Standard Application
- Drivers
- User Guide
- SDK (API, examples, documentation)

The Standard Application provides control of set-up commands demonstrating cameras performance.

API allows full control of all camera features and along with examples and documentation enables easy integration of the camera into the customers' applications.

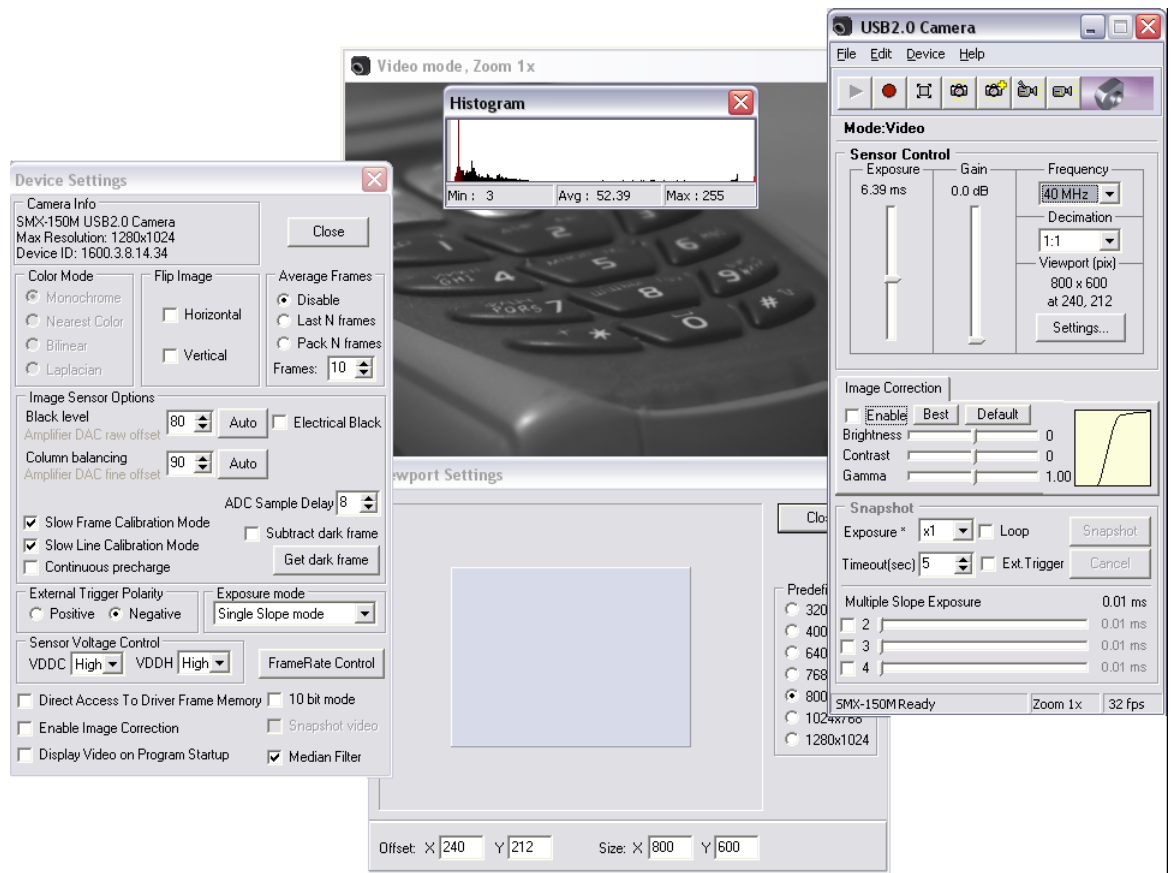

Figure 1-11 SMX-150M application

Drivers

- WDM compatible
- Twain included
- Linux (upcoming)

System requirements

- Windows 7 or XP 1 and higher

For more information, see [“System requirements” on page 7](#).

API function categories

- Get camera info
- Get/Set camera features
- Video stream controls (Start/Stop)
- Image grabbing
- Image correction controls (brightness, contrast, and gamma)

- Snapshot controls (Exposure)
- Open /Close camera

Camera application controls

- Image correction (Brightness, Contrast, Gamma)
- Viewport
- Image capture
- Video capture
- Global shutter video mode
- Selectable Exposure, Gain and Frequency (sensor controls)
- Decimation (1:1 and 1:2)
- Histogram
- Software zoom
- Selectable (8 bits or 10 bits) mode output
- Multiple slope mode (Global shutter)
- Double slope mode (Rolling shutter)
- Auto Exposure
- Frame rate control
- ADC timing - selectable
- Black Level (Amplifier DAC raw offset) - auto and selectable
- Column balancing (Amplifier DAC fine offset) - auto and selectable
- Sensor voltage control - selectable
- Horizontal and Vertical flipping
- Averaging frames

The set of examples included into SDK serves as a tutorial in developing new applications.

Third-Party IDE/Software Compatibility

The SMX-150M USB2.0 Cameras are compatible with the following programming environments and software:

- Visual Studio 6.0 (2002, 2003, 2005, 2008, 2010) (SDK)
- Delphi/Builder C++ (SDK)
- C# (SDK)

- C# 2003, 2008
- C++ Net
- HALCON (SDK) (upcoming)
- LabVIEW (SDK)
- MATLAB (SDK)
- Strepix (SDK)
- Visual Basic 6.0 (SDK)

Assistance and Help

Our developers are ready to advise and assist with integration of SDK into relevant applications.

Camera Customization

Sumix Corporation offers hardware and software customization services to meet customers' specific needs. Recent camera custom development examples:

- Camera case mechanical modification
 - External trigger output mode customization
 - Unique sensor modification
-

Camera Accessories

The **SMX-150M USB2.0 Cameras** usually go with:

1. Tripod adapter. The lightweight duralumin adapter allows quick and easy camera fixing to the tripod, offering additional protection of the camera

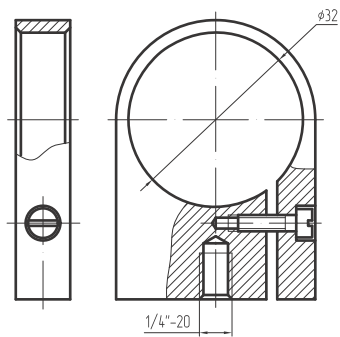

2. USB A to Mini B cable, 1.75 m long

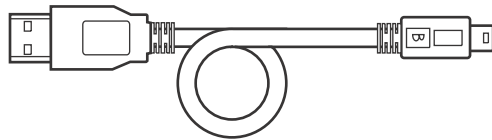

3. 6 pin Hirose trigger connector (without a cable)

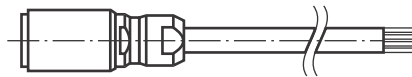

Sample Images

Use of Multi Slope with Global shutter. The pictures below show the image from the SMX-150M camera before and after Multi Slope use:

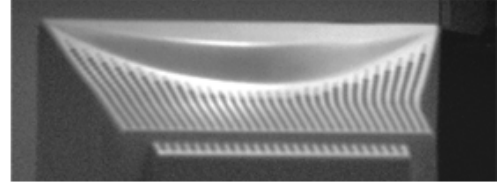
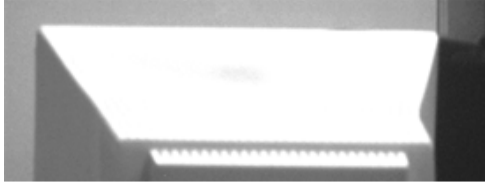

Figures

Camera drawing	8
SMX-150M camera outlook	9
Pinout	9
Spectral response characteristics	10
Photo-voltaic response curve	11
Architecture of the 4T-pixel	12
Transmission characteristics of the D263 glass used as protective cover for the IBIS5A-1300 sensors (monochrome)	13
Multiple slope response	13
Double slope response	14
Linear and non-linear ADC conversion characteristics	15
SMX-150M application	16



*2 rue Henri Janin 78470 ST REMY LES CHEVREUSE
Tel : 01 30 47 45 86 - Fax : 01 30 47 93 37
contact@sacasa.info - www.sacasa.info*
