

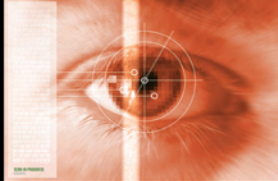

BOBCAT

INTELLIGENT CAMERA SERIES

ICL-B2020



The **ICL-B2020** is an advanced high-speed progressive scan, fully programmable CCD camera designed for imaging applications that require high frame rates, high quality images, and powerful features and flexibility. The camera has a small size, light weight, and is built around Kodak's KAI-4022 Interline transfer CCD image sensor with a 1.3" optical format (21.5 mm image diagonal). ICL-B2020 is available with CameraLink output.

The B2020 provides an image resolution of 2056 x 2060 and delivers up to 20.4 frames per second at full resolution. The camera image processing engine is based on a high-speed, high-density FPGA, featuring programmable resolution, speed, 8 independent AOIs, binning, triggering, exposure control, line and frame time, I/O mapping, external/internal sync, AGC, AEC, Auto Iris, transfer function correction, user LUT, Defective and Hot Pixel Correction (DPC, HPC), and Flat Field Correction (FFC).

Features

- 2056/2048 x 2060/2048
- Mono and color - 8/10/12/14-bit data
- Normal and over-clock operation (16.3/20.4 fps)
- Base CameraLink
- Two dimensional Flat Field Correction
- RS232 serial communication
- Analog and digital gain and offset control
- 1x, 2x, 3x, 4x, 8x horizontal and vertical binning
- Eight (8) independent horizontal and vertical AOIs
- Programmable horizontal and vertical resolution
- Programmable line time, frame time and speed
- Programmable external trigger:
 - 3 triggering sources
 - 5 triggering modes
- Automatic gain, exposure and iris control

- Internal/External exposure control
- Internal/External H and V sync input/output
- Left/right digital bit shift
- Test image with image superimposition
- Built in pulse generator
- Programmable I/O mapping
 - 4 programmable inputs
 - 3 programmable outputs
- Dynamic transfer function correction
- Dynamic black level correction
- Defective and hot pixel correction
- Temperature monitor
- Field upgradeable firmware, LUT, DPC, HPC, FFC

Applications

- Industrial
- Medical
- Microscopy
- Military
- Scientific
- Surveillance

SACASA INDUSTRIES ET SYSTEMES
2 rue Henri Janin – 78470 ST REMY LES CHEVREUSE
Tel : 01 30 47 45 86 – Fax : 01 30 47 93 37
info@sais.fr – www.sais.fr

Specifications for Bobcat ICL-B2020

Maximum Resolution	2056 x 2060
Sensor Type	21.5 mm diagonal, CCD KAI-4022
Pixel Size	7.40 μ m
Frame Rate	16.3/20.4 fps (normal/overclock)
Max Frame Rate	156 fps
Minimum S/N ratio	60 db
Video output	Base Camera Link, mini CL interface
Output format	8, 10, 12 bit dual, 8, 10, 12, 14 bit single
Binning H & V	x1, x2, x3, x4, x8
Area of Interest	8 independent AOIs, 2 x 2 to 2056 x 2060
Shutter Speed	1/100000 to 1/16 sec
Long integration	Up to 16 sec
Gamma correction	G=1.0, G= 0.45, user upgradable LUT
Video gain	36 dB range, 1024 steps, 0.0351 dB per step
Exposure and AGC	Manual, Auto, Programmable
Iris Control	Auto, Programmable
Hardware trigger	LVTTTL or TTL via IN1/IN2, optically isolated, level, edge, pulse-width, programmable
Software trigger	Frame-grabber via CC1/CC2, level, edge, pulse-width, programmable
Trigger modes	Programmable, standard, double exposure, fast, frame accumulation, asynchronous
Strobe output	Programmable position and duration
Image Overlay	Yes, Programmable
RS232 Interface	Yes
Data Corrections	DPC, HPC, LUT, FFC
Min. illumination	1 Lux, F/1.4
Power input range	12 VDC, (10 V – 15 V)
Power consumption	3.6 W PoCL
Size (W x H x L), Weight	60 x 60 x 38mm, 280g
Lens Mount	F mount
Vibration, Shock	10G (20 - 200)Hz XYZ, 70G
Environmental	Operation (-30° to 60°) C, storage (-40° to 70°) C
Humidity	10% to 90% non-condensing

Power and I/O Interface

Connector: Hirose HR 10A-10R-12PB(71)

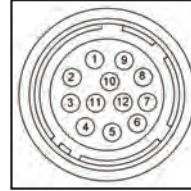

- | | |
|------------------------|------------------------|
| 1 12V DC Return | 7 OUT1 Signal |
| 2 +12V DC | 8 IN1 Signal |
| 3 IRIS VCC | 9 IN2 Signal |
| 4 IRIS Video | 10 IN1/2 Return |
| 5 IRIS Return | 11 Reserved |
| 6 OUT1/2 Return | 12 OUT2 Signal |

Power Requirements

12V DC, (10V min, 15V max)
300 mA steady, 1.5 A inrush
3.6 W PoCL

Accessories

PS12V04: Power Supply (sold separately)

Ordering Information

Ordering: **ICL-B2020M-KFO**

Camera Family

B-Bobcat Family

Sensor Type

M-Monochrome

C-Color

Lens Mount

F-“F” Mount (default)

C-“C” Mount

CCD

K-Kodak

Spectral Response

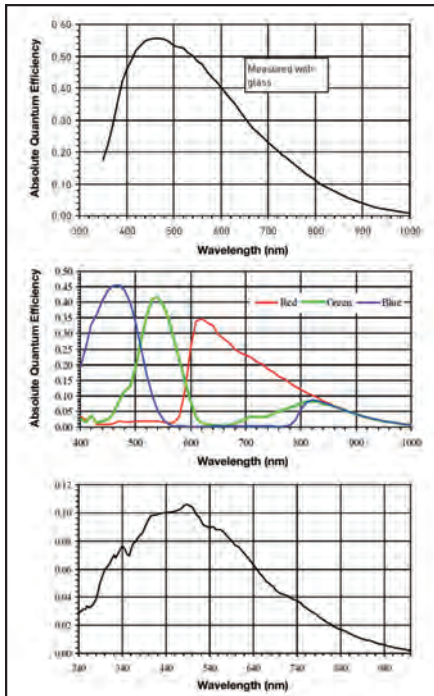

Configuration Utility



Mechanical Dimensions

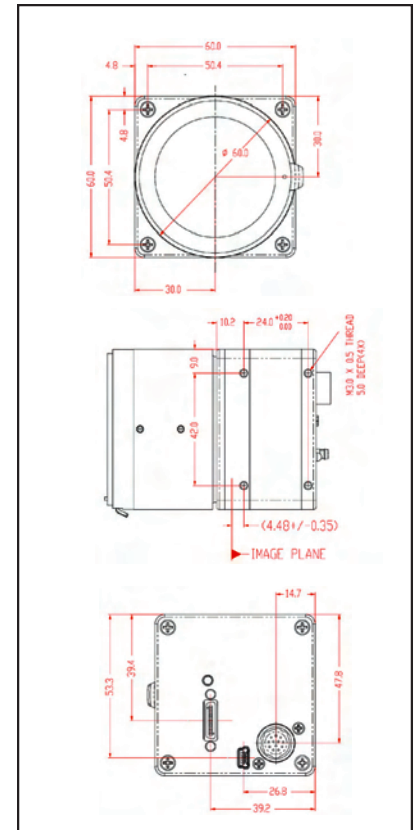

For specific details and ordering information, consult the camera user's manual or contact us at sales@imperx.com.