



Rack mount Dual Screen LCD Drawer Combination

Best Choice for your multitasking operation

4 Displays Aggregation

Features

Rack mounting dual 17.3" FHD displays have been extended to a new application – 4 Displays Aggregation Console:

- Total 17U height on the rack space with outstanding multitasking performance
- Total 4U height in the space-saving storage
- Independent keyboard / touchpad to control below unit.

Combination

- 1 x RMD-17W-D2-U, a flip down dual screen drawer
- 1 x KVMD-1701W-D2, a dual rail dual screen LCD console with keyboard/mouse operating independently

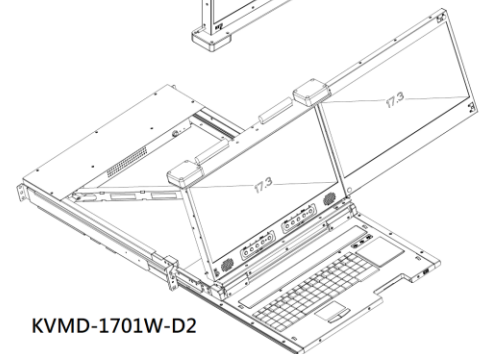
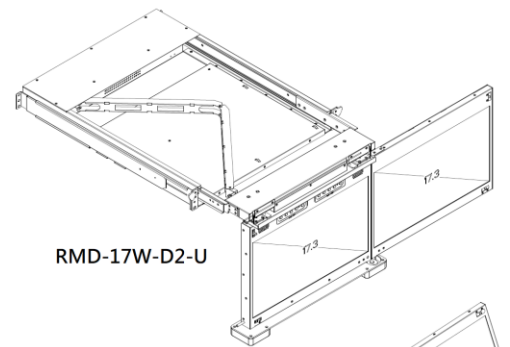
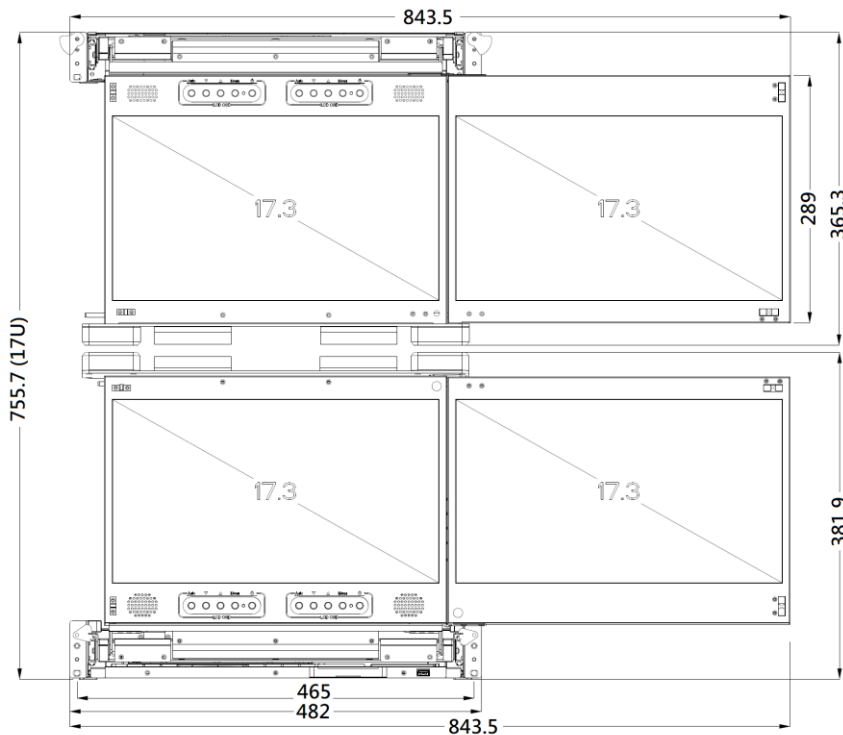

Rack mount Dual Screen LCD Drawer Combination

Best Choice for your multitasking operation

4 Displays Aggregation

Upper unit – RMD-17W-D2-U



Features

- 2U flip-down foldable dual 17.3 inch widescreen LCD display Drawer
- Dual DVI & VGA Port
- 1920 x 1080 high resolution
- Support FHD with 1080p resolution.
- Build in 2x 2 watts speakers
- Independent front osd control buttons to optimized display
- Adjust angle 0°~90°

Options

- Composite video input
- HDMI or Display port input
- 3G / HD / SD-SDI broadcast grade input
- DC 9~36 V power input
- AR Hardness glass
- Touch screen

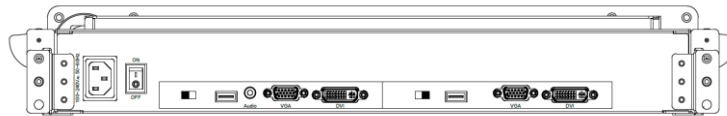

Rear of RMD-17W-D2-U

Part No.		RMD-17W-D2-U
No. of ports		1
KVM Connectors		2 x DVI-D & 2 x VGA / 1x Audio
LCD	Size	Dual 17.3 inch FULL HD display
	Backlight	LED
	Resolution	1920*1080 (support resolution up to 1920*1200)
	Max.color	262K
	Luminance	300 cd/m2
	View Angel (H/V)	140 / 120
	Contrast Ratio	650 : 1
Port Selection		N/A
Audio		1 x 3.5mm Audio jack
Rack Depth (rack cabinet front rails to rear rails)		580mm to 950mm
Power		100-240V AC 50/60Hz via IEC Type power cord
Environment		Operation temp: 0 to 50°C Storage temp: -20 to 60°C Humidity: 10% - 90%, non-condensing Shock: 10G acceleration (11ms duration) Vibration: 17 to 500Hz 1G PTP
Physical Dimensions (W x H x D) / Net Weights (KGs)		443 x 75 x 580mm / 18.5
Packing Dimensions (W x H x D) / Gross weights (KGs)		735 x 590 x 235mm / 23.0
Accessory		
RMD-17W-D2-U	1.8meter IEC Type Power Cord x1 , 1.8meter DVI Cable x2 , 1.8meter VGA Cable x2 ,1.8meter Audio Cable x1	

Rack mount Dual Screen LCD Drawer Combination

Best Choice for your multitasking operation

4 Displays Aggregation

Lower unit – KVMD-1701W-D2

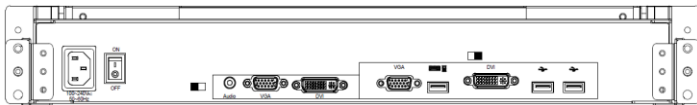

Rear of KVMD-1701W-D2

Features

- 2U Dual 17.3 inch widescreen LCD Console Drawer
- Dual DVI & VGA Port
- 1920 x 1080 Ultra high resolution
- Support FHD with 1080p resolution.
- Dual rail design, capable the LCD screen and keyboard tray Operated independently.
- Front 1xUSB, Rear 2xUSB 2.0 Type A, Sharing USB peripheral Device for computer (ex, flash disk, hard driver, KB/Mouse)
- 104-key keyboard with touch pad mouse.
- USB 2.0 Keyboard & Mouse
- Build in 2x 2 watts speakers

Options

- Composite video input
- HDMI or Display port input
- 3G / HD / SD-SDI broadcast grade input
- DC 9~36 V power input
- AR Hardness glass
- Touch screen

Part No.		KVMD-1701W-D2
No. of ports		1
KVM Connectors		2 x DVI-D & 2x VGA / 1 x USB for KB & Mouse / 1x Audio
LCD	Size	Dual 17.3 inch FULL HD display
	Backlight	LED
	Resolution	1920*1080 (support resolution up to 1920*1200)
	Max.color	262K
	Luminance	300 cd/m2
	View Angel (H/V)	140 / 120
	Contrast Ratio	650 : 1
Port Selection		N/A
USB HUB		Yes , Front x1 & Rear x 2 USB 2.0 Type A for USB Peripheral Device
Audio		1 x 3.5mm Audio jack
KB/Mouse Emulation		USB 2.0
Rack Depth (rack cabinet front rails to rear rails)		580mm to 950mm
Power		100-240V AC 50/60Hz via IEC Type power cord
Environment		Operation temp: 0 to 50°C Storage temp: -20 to 60°C Humidity: 10% - 90%, non-condensing Shock: 10G acceleration (11ms duration) Vibration: 17 to 500Hz 1G PTP
Physical Dimensions (W x H x D) / Net Weights (KGs)		443x67x580mm / 21.0
Packing Dimensions (W x H x D) / Gross weights (KGs)		735x590x215mm / 24.0
Accessory		
KVMD-1701W-D2	1.8meter IEC Type Power Cord x1 , 1.8meter DVI Cable x2 , 1.8meter VGA Cable x2 , 1.8meter USB Cable x1 ,1.8meter Audio Cable x1	

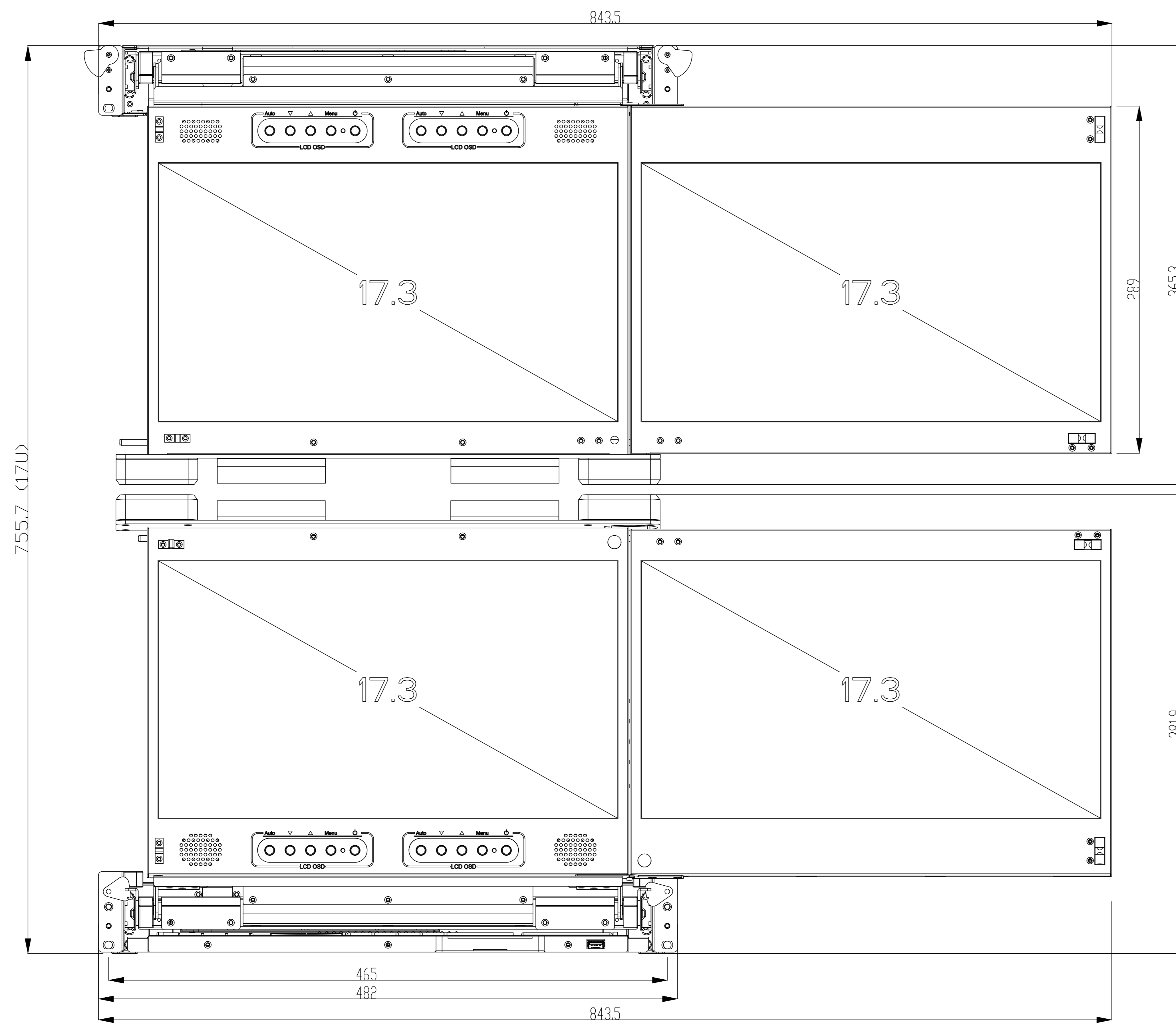

RMDU-17WD2

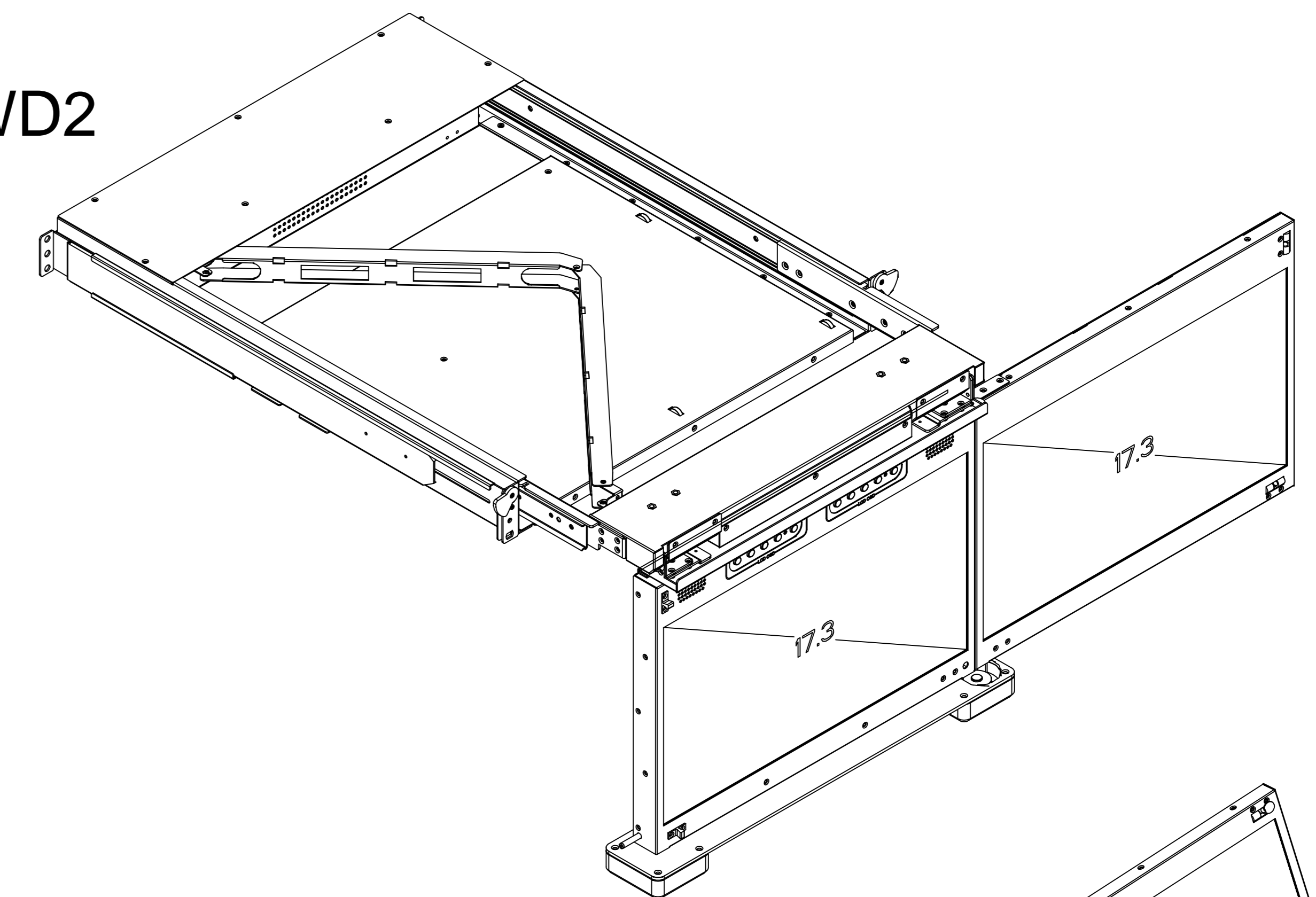

KVMD-17WD2

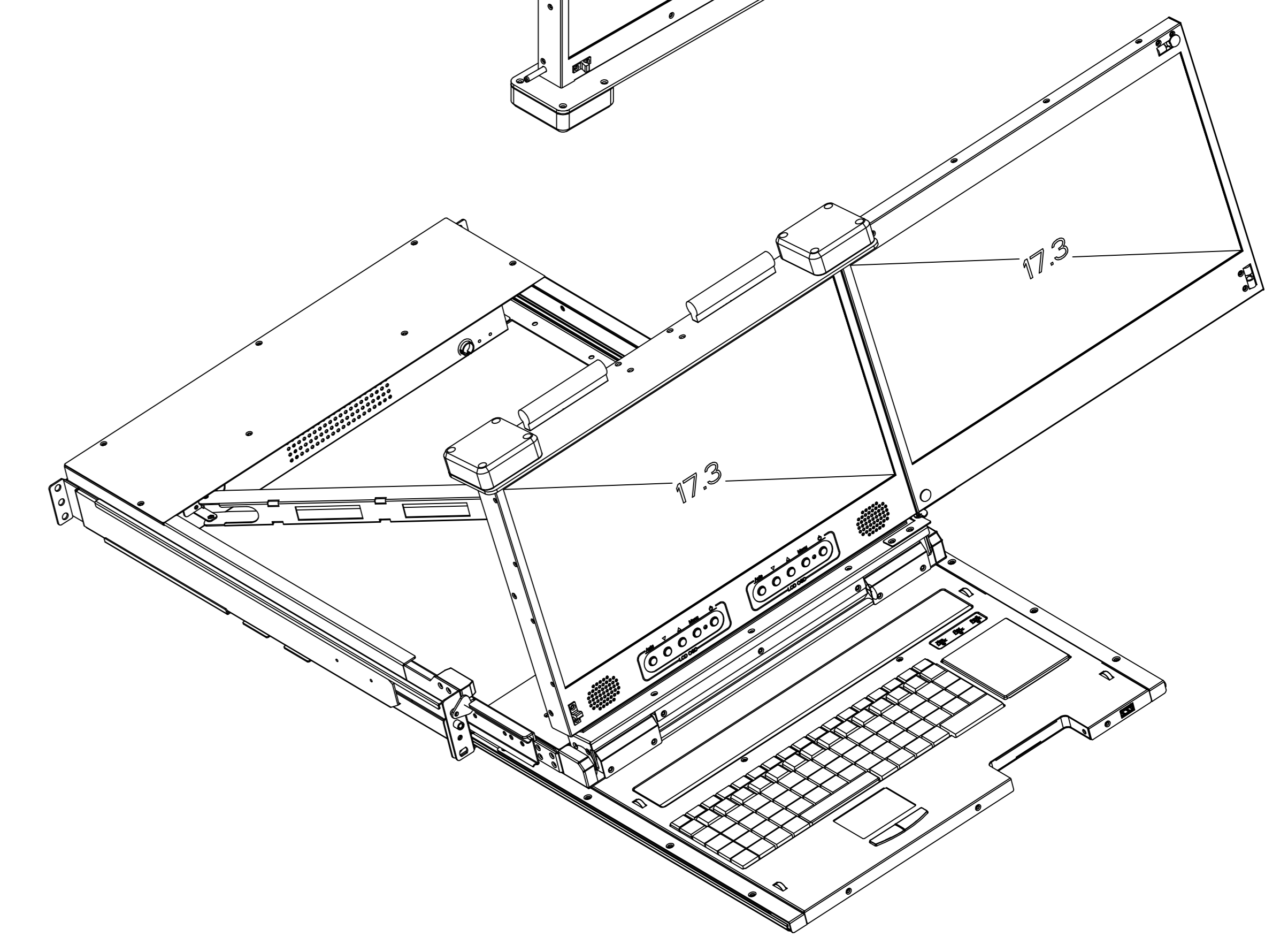

MARK	DESCRIPTION	SING	DATE
△			
△			
△			

		1、绿色面	2、白色面									
TOL	< 30	: ±0.1		UNIT : mm	FINISHING		PART NO.		Ver.	A0		
	30 < 120	: ±0.15			3RD ANGLE'S	MATERIAL	SGCC T=1.0mm	MOLD NO.	RMDU-17WD2	Q'ty	1	
	120 < 315	: ±0.2			APPROVED			TITLE	RMDU-17WD2			
	315 <	: ±0.3			CHECKED			DRAWING NO.	RMDU-17WD2.DWG			
	ANGLE TOL	: ±0.5°		DRAWN			SIZE	A3	SCALE	0.2	SHEET: 1 OF 1	
