

# DT9832 and DT9836

## High Performance, Isolated Simultaneous USB Data Acquisition

The DT9832 and DT9836 are a series of high-speed, high performance USB data acquisition modules that provide **simultaneous analog input operation at up to 2.0MHz per channel**. Each analog input has its own A/D converter to **eliminate phase shift between channels** and to allow you to **correlate measurements** at the exact same instant in time. Each USB DAQ module features three quadrature decoders for measuring absolute and relative position and for detecting rotational speed.

### Key Features:

- 2, 4, 6, or 12 Simultaneous, 16-bit A/D channels
- 2 Simultaneous, 16-bit deglitched D/A channels (4 available on the DT9836)
- **Fast sampling rates:** up to 2.0MHz/channel
- **Two 32-bit C/T**, three 32-bit quad decoders
- **32 digital I/O lines**
- **±500V galvanic isolation...**prevents ground loops
- **Synchronous subsystem operation:** A/D, D/A, DIO, C/T, Q/D
- **Compatible with LabVIEW and MATLAB**
- **Includes free QuickDAQ software...**get up and running quickly
- **OEM board-level only version available**

### Synchronous Operation

All functions of the data acquisition modules (A/D, D/A, DIO, Counter Timers, and Quadrature Decoders) can be simultaneously triggered internally or externally. The data can then be streamed synchronously to host memory. This can be done via external trigger or by the internal clock of the module. The synchronous operation allows all I/O data to be processed and correlated for all inputs and outputs. This is very valuable in determining the response across a device-under-test (DUT) to stimuli at the same exact instant.



Figure 1. The DT9836, shown in BNC connection box, provides simultaneous analog inputs at up to 225 kHz per channel.

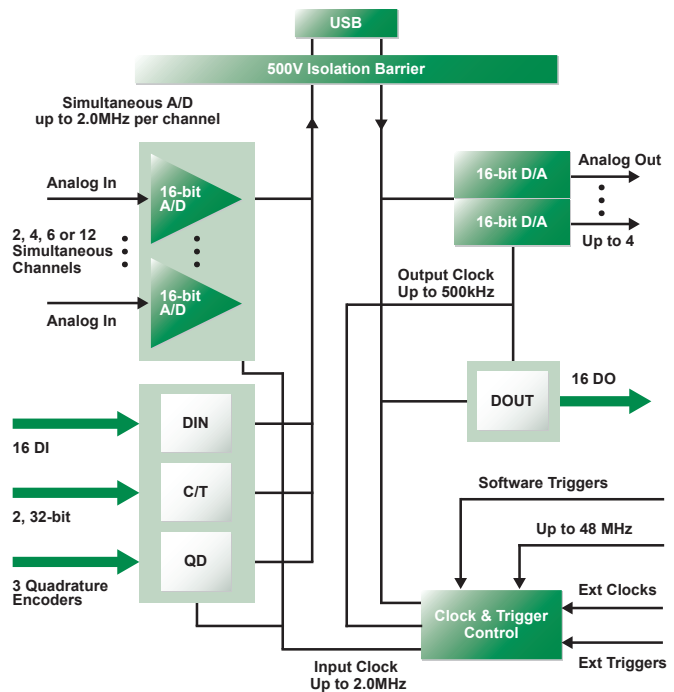

Figure 2. The DT9836 and DT9832 Series provides USB 2.0 multifunction modules for simultaneous operation of analog input, analog output, digital I/O, and counter/timer subsystems.

Features Summary									
Model	Analog Inputs	Resolution	Input Range	Sample Rate	Digital I/O	C/Ts	Quadrature Decoders	Analog Outputs	Isolation
DT9832 Series	2 or 4 SE	16-bit	±10V	Up to 2 MHz/ch	16 in, 16 out	2	3	0 or 2	±500 V
DT9836 Series	6 or 12 SE	16-bit	±5V, ±10V	225 kHz/ch	16 in, 16 out	2	3	0, 2, or 4	±500 V

## Simultaneous, High Accuracy Performance

The High Performance DT9832 and DT9836 Series provides simultaneous analog input operation. Each analog input has its own A/D converter to eliminate phase shift between channels — a problem with multiplexed architectures where all inputs share one A/D converter. As a result, this Series allows you to correlate simultaneous measurements.

**Precision Measurements...**  
True 16-bit A/D at up to 2.0MHz throughput per channel for measuring multiple input signals simultaneously

**No Limits...**  
Full simultaneous and synchronous operation of all subsystems.

**Designed for Low Noise...**  
12-layer PCB provides optimal grounding and shielding to maintain signal integrity

**Fully Protected...**  
±500V galvanic isolation protects your computer and maintains signal integrity

**High-Speed USB 2.0...**  
USB 2.0 connector for data transfer at up to 480Mbps

**Simultaneous Analog Inputs...**  
2, 4, 6 or 12 simultaneously sampled analog input channels (depending on model)

**Ultra Digital I/O...**  
Full digital I/O flexibility for time stamping, pattern recognition, and synchronizing with external events

**Three Quadrature Decoders...**  
For X/Y positioning and rotation (tachos)

**External Control...**  
Flexible clocks and triggers

**Flexible Power Connections...**  
+5 V connector; a secondary +5 V connector is provided for embedded applications

**Full-featured Flexible Counter/Timers...**  
Two 32-bit counter/timers ideal for testing applications.

## Selection Criteria: Nyquist and Bandwidth Limits Determine Model Choices

Each model has been designed to accurately measure higher bandwidth signal components. To accurately measure 16-bit accuracy, the front-end input amplifier has a bandwidth of ten times the Nyquist limit. Below are examples of these design characteristics for each board.

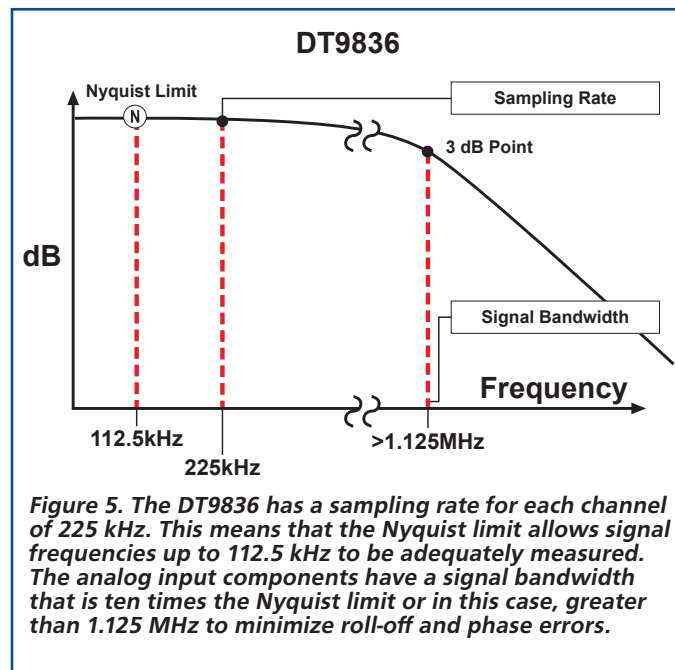
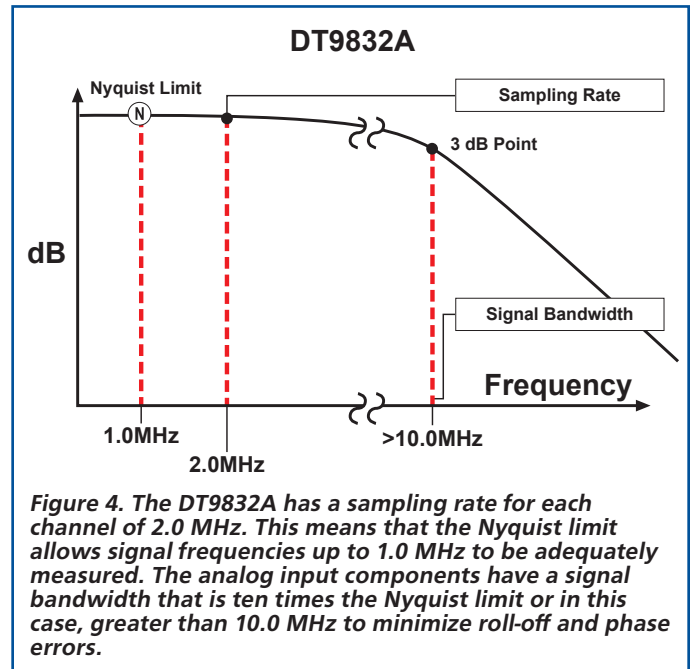
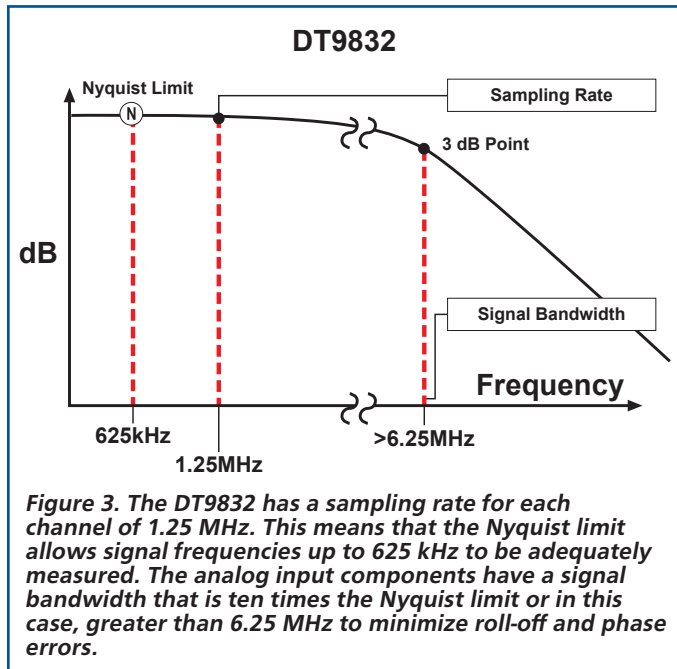



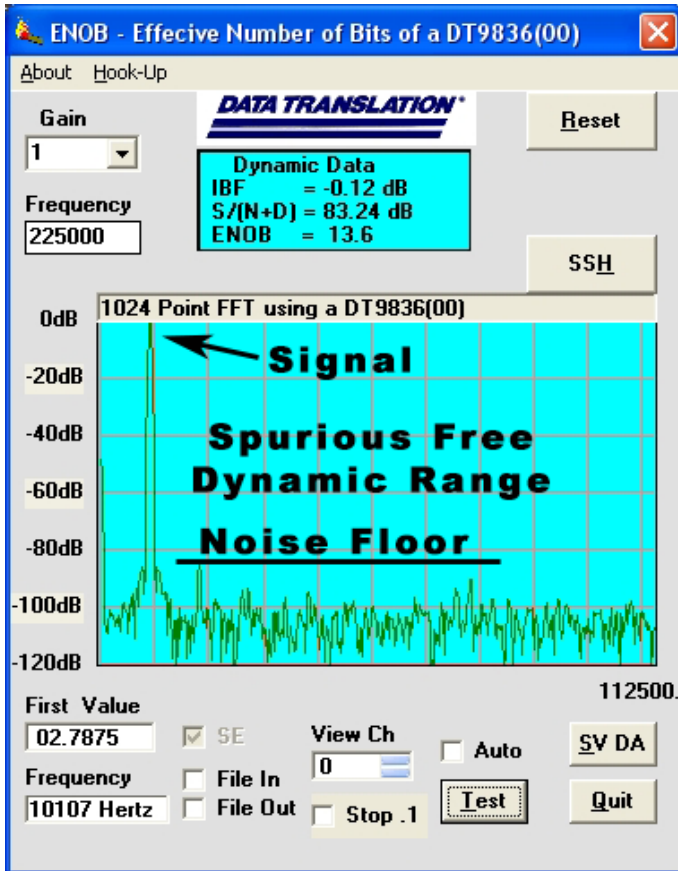
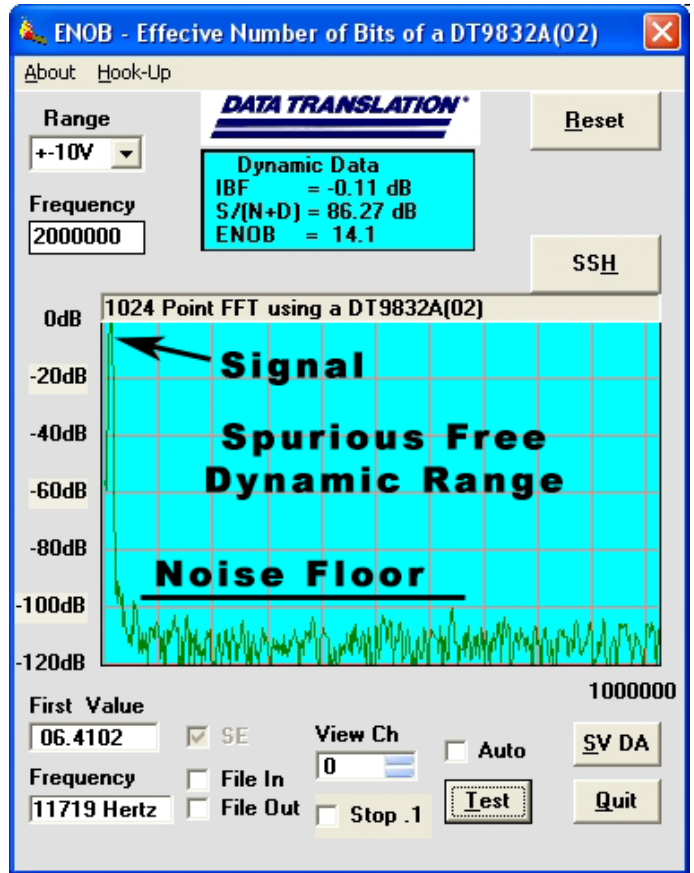
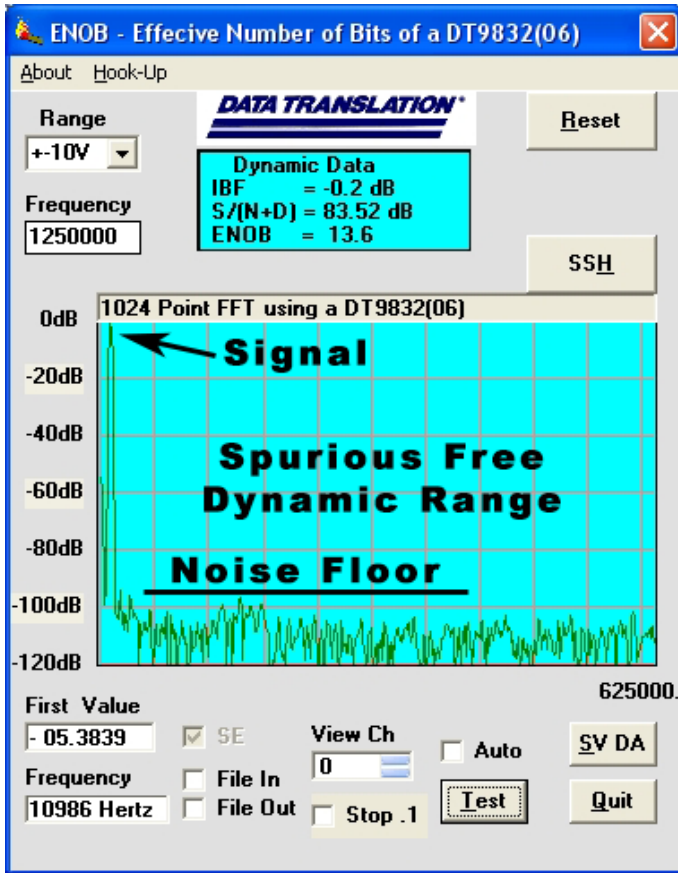
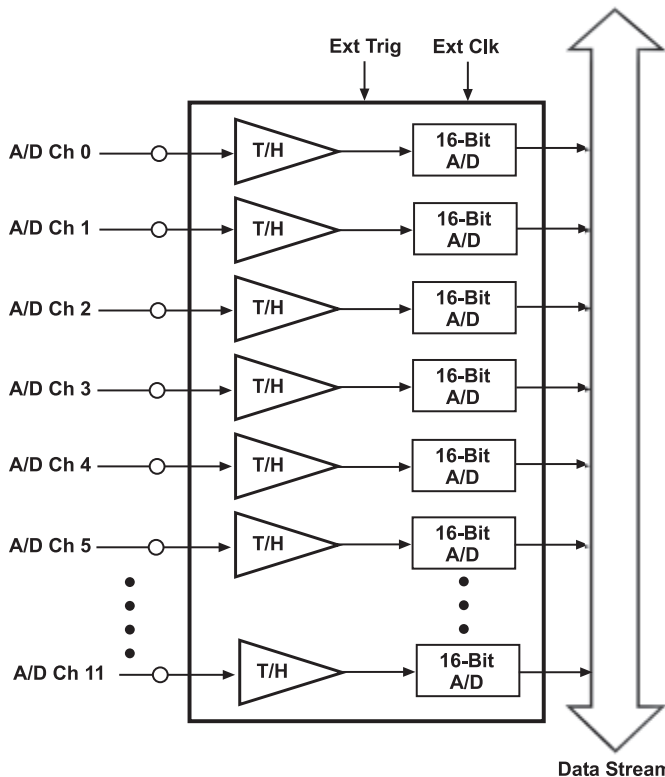

Figure 7. These graphs show the outstanding quality of the DT9832 Series and DT9836 Series for all error sources... with ENOB (Effective Number Of Bits) ratings of 13.6, 13.6, and 14.1 bits respectively and an SFDR (Spurious Free Dynamic Range) of 86dB to 95dB.

## Closely Matched Analog Inputs

The isolated analog inputs of the DT9832 and DT9836 Series have been designed to match each other with high precision. Each input has its own separate high impedance 16-bit A/D converter. The impedance has been carefully matched for each of the inputs so that one looks exactly like the other. The data acquisition board has 12-layers in its make-up to adequately shield and protect each signal path etch from the high speed transitions of the digital lines. The slightest mismatch would result in DC and AC errors in measurement when trying to correlate readings at the same instant in time.



**Figure 8.** The DT9836 Series features 6 or 12 independent, successive-approximation A/D converters with track-and-hold circuitry. Each converter uses a common clock and trigger for simultaneous sampling of all analog inputs at 225kS/s per channel. The DT9832 Series features 2 or 4 simultaneous A/D converters with sampling rates up to 2.0 MHz.

The SFDR plot in Figure 7 gives the best indication of the match of these DC and AC characteristics. The AC dynamic performance at high switching speeds for all channels shows overall accuracy to be better than 13.6 bits. This is worst case with all errors shown in the FFT ENOB plot. This performance is beyond any other data acquisition system available.

## High-Speed, High-Resolution Analog Outputs

There are 2 simultaneous 16-bit analog outputs, and an option for 4 outputs, on the DT9836 Series, composed of separate high speed, deglitched, waveform D/A converters. This design allows highly accurate arbitrary waveforms to be generated at throughput speeds of 500 kHz each. Standard waveforms such as sine, triangle, and square waves are easily produced by loading the output memory and triggering them synchronously or separately. Great care has been used in design to minimize the glitch energy for any major or minor carry. This results in extremely smooth waveforms.

## Flexible Output Modes

Using the DT9832 and DT9836 series, you can output a single value from a single analog output channel or multiple values from multiple analog output channels. An output channel list gives you the flexibility of updating only the analog output channels you want or updating the digital output lines with specified analog output channels at the D/A clock rate. You can update analog output channels at up to 500 kSamples/s.

Both Series feature the following output modes:

- **Continuous output mode** — Choose this mode if you want to accurately control the period between conversions of individual output channels in the output channel list.
- **Waveform mode** — Use this mode if you want to output waveforms repetitively from an output FIFO on the module, minimizing communication overhead with the host computer. If you specify only one channel in the output-channel list, you can load a waveform containing up to 128 kSamples into the output FIFO. If you specify all the analog output channels and the digital output lines in the output-channel list, you can load a waveform containing up to 24 kSamples into the output FIFO. Using waveform mode, you can update multiple channels at up to 500 kSamples/s.

## High-Speed Digital I/O Lines

The DT9832 and DT9836 Series modules feature 32 digital I/O lines dedicated as 16 in and 16 out. The first eight digital input lines can also be used for interrupt on change. You can read all the digital input lines simultaneously with the analog input channels at the A/D clock rate. The digital input lines can also be clocked separately as the only channel in the channel-gain list at up to 225 kHz on the DT9836, 1.25 MHz on the DT9832, and 2.0 MHz on the DT9832A.

For digital output operations, you can update all the digital output lines with the analog output channels at the D/A output clock rate.

Note: Continuous digital output operations are not supported on modules that do not have analog output channels.

All lines are EMI protected to minimize interference from transient signals.

## Multifunction Counter/Timers

All DT9832 and DT9836 Series modules feature two 32-bit user counter/timers. If you wish, you can read the value of the counter/timer channels with the analog input channels and digital input lines at the A/D clock rate. The following counter/timer functions are supported: event counting, up/down counting, frequency measurement, edge-to-edge measurement, continuous edge-to-edge measurement, rate generation, one-shot, and repetitive one-shot.

## Quadrature Decoder

The Quadrature Decoder module contains three quadrature decoders which allow simultaneous decoding of three quadrature encoded inputs. The quadrature decoders may be used to provide relative or absolute position or, by calculating the difference between samples, the rotational speed. Each quadrature decoder supports "A", "B", and "Index" inputs. The index input may be used to zero out the positional count and the A and B input relationships are used to increment or decrement the positional count.

Each decoder features a digital input filter that is programmable from 27ns to 7µs for the DT9836 Series and from 20ns to 5µs for the DT9832 Series. This unique filtering capability helps remove ringing edges and unwanted noise.

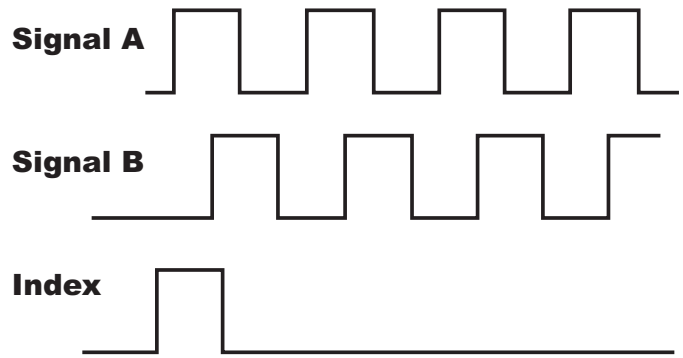

Figure 9. A quadrature decoder takes the output signals (A, B, and Index) for the quadrature encoder as inputs and converts these signals into a numerical value that can be used to determine position, distance, velocity, and other functions.

## Flexible Clocks and Triggers

For maximum flexibility, all DT9832 and DT9836 Series modules provide independent clocks and triggers for the A/D and D/A subsystems. This allows you to trigger and clock the analog output subsystem synchronously with, or independent of, the analog input subsystem. Each subsystem supports an internal clock and external clock input, as well as the following trigger types: software command, analog threshold, and external digital input trigger.

## Power

The BNC connection box option includes a separate +5V power supply and power cable for quick setup. OEMs can purchase these options separately as EP361. A secondary power connector is also provided for OEMs to allow custom power wiring.

## ±500V Galvanic Isolation Protects Your Data

Computers are susceptible to ground-spikes through any external port. These spikes can cause system crashes and may even cause permanent damage to your computer. These modules feature ±500 Volts of galvanic isolation to protect your computer from ground-spikes and to ensure a reliable stream of data.

## EMI and ESD Design Criteria

The DT9832 and DT9836 Series has been designed to perform with the lowest noise characteristics. Damping resistors in series with every I/O line minimize ringing and EMI and provide current limits that protect against transient signals.

## QuickDAQ

QuickDAQ allows you to acquire and display from all Data Translation USB and Ethernet data acquisition devices that support analog input streaming. Combine QuickDAQ with Data Translation hardware to acquire data, record data to disk, display the results in both a plot and digital display, and read a recorded data file. Be productive right out of the box with this powerful data logging software. Data can be exported to other applications like Microsoft Excel® and The Mathworks MATLAB® for more advanced analysis. Two additional options can be purchased to add FFT analysis capabilities to the base package.

### Key Features:

- **QuickDAQ Base Package (Free)**
  - Ready-to-measure application software
  - Configure, acquire, log, display, and analyze your data
  - Customize many aspects of the acquisition, display, and recording functions to suit your needs
- **FFT Analysis Option (License Required)**
  - Includes all the features of the QuickDAQ Base Package
  - Perform single-channel FFT operations including:
    - ◆ Auto Spectrum
    - ◆ Spectrum
    - ◆ Power Spectral Density
  - Configure and view dynamic performance statistics
  - Supports Hanning, Hamming, Bartlett, Blackman, Blackman Harris, and Flat Top response windows
- **Advanced FFT Analysis Option (License Required)**
  - Includes all the features of the QuickDAQ Base Package and FFT Analysis Package
  - Perform 2-channel FFT operations including:
    - ◆ FRF
    - ◆ Cross-Spectrum
    - ◆ Cross Power Spectral Density
    - ◆ Coherence
    - ◆ Coherent Output Power
  - Supports real, imaginary, and Nyquist display functions
  - Additional FFT analysis functions supported: Exponential, Force, Cosiner Taper
  - Save data to .uff file format

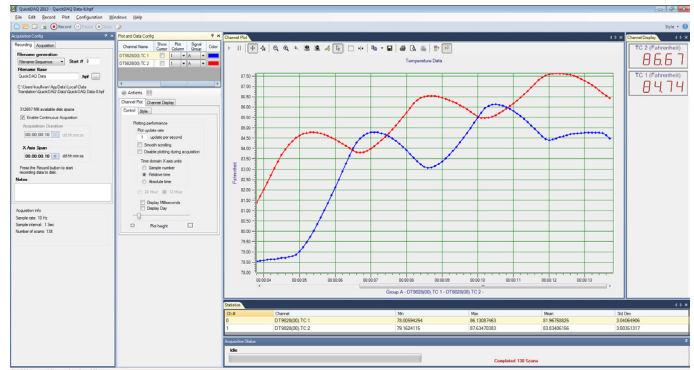

Figure 10: QuickDAQ ships free-of-charge and allows you to get up and running quickly.

## Other Software Options

There are many software choices available for application development, from ready-to-measure applications to programming environments.

The following software is available for use with a DT9832 Series or DT9836 Series module and is provided on the Data Acquisition Omni CD:

- **DT9832/DT9836 Device Driver** — The device driver allows you to use a DT9832 Series or DT9836 Series module with any of the supported software packages or utilities.
- **DT9832/DT9836 Calibration Utility** — This utility allows you to calibrate features of a DT9832 Series or DT9836 Series module.
- **Quick DataAcq** application — The Quick DataAcq application provides a quick way to get up and running. Using this application, verify key features of the module, display data on the screen, and save data to disk.
- **DT-Open Layers® for .NET Class Library** — Use this class library if you want to use Visual C#® or Visual Basic® for .NET to develop application software using Visual Studio® 2003-2012; the class library complies with the DT-Open Layers standard.
- **DataAcq SDK** — Use the Data Acq SDK to use Visual Studio 6.0 and Microsoft® C or C++ to develop application software using Windows® XP/Vista/7/8; the DataAcq SDK complies with the DT-Open Layers standard.
- **DAQ Adaptor for MATLAB** — Data Translation's DAQ Adaptor provides an interface between the MATLAB® Data Acquisition (DAQ) toolbox from The MathWorks™ and Data Translation's DT-Open Layers architecture.
- **LV-Link** — Data Translation's LV-Link is a library of VIs that enable LabVIEW™ programmers to access the data acquisition features of DT-Open Layers compliant USB and PCI devices.

## Flexible Packaging Configurations

The DT9832 and DT9836 Series modules are available in two packaging configurations: a BNC connection box and an OEM embedded version. The BNC configurations are enclosed in metal boxes with standard BNC and DSUB connectors, 2 BNCs for connecting analog outputs, and 4 BNCs for connecting external clocks and triggers. The BNC configuration ships with a +5 V galvanically isolated power supply and power cable, USB 2.0 cable, and Data Acquisition OMNI CD.

The OEM configuration, ideal for embedding in test systems, provides all the functionality of the DT9832 and DT9836 Series in PC-board form. This configuration ships with a USB 2.0 cable and Data Acquisition OMNI CD.

## Cross-Series Compatibility

Virtually all Data Translation data acquisition modules are compatible with the DT-Open Layers for .NET Class Library. This means that if your application was developed with one of Data Translation's software products, you can easily upgrade to a new Data Translation board. Little or no reprogramming is needed.

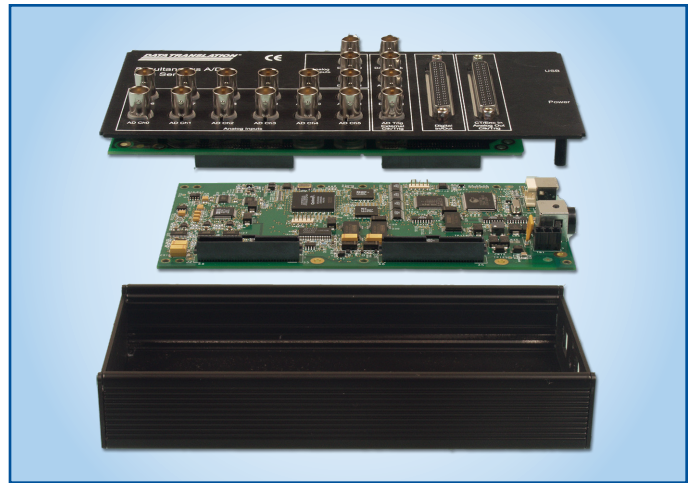

*Figure 11. The BNC connection box packages the OEM embedded versions of the board in a CE-compliant enclosure.*



## Ordering Summary

DT9832							
Model	Analog In	Analog Out	Throughput	Digital In/Out	C/T	Q/D	Package
DT9832-04-0-BNC	4SE	0	1.25 MHz	16 / 16	2	3	BNC
DT9832-04-2-BNC	4SE	2	1.25 MHz	16 / 16	2	3	BNC
DT9832-04-2-OEM	4SE	2	1.25 MHz	16 / 16	2	3	OEM
DT9832A							
DT9832A-02-2-BNC	2SE	2	2.0 MHz	16 / 16	2	3	BNC
DT9832A-02-2-OEM	2SE	2	2.0 MHz	16 / 16	2	3	OEM
DT9836							
DT9836-06-0-BNC	6SE	0	225 kHz	16 / 16	2	3	BNC
DT9836-06-0-OEM	6SE	0	225 kHz	16 / 16	2	3	OEM
DT9836-06-4-BNC	6SE	4	225 kHz	16 / 16	2	3	BNC
DT9836-06-4-OEM	6SE	4	225 kHz	16 / 16	2	3	OEM
DT9836-12-2-BNC	12SE	2	225 kHz	16 / 16	2	3	BNC
DT9836-12-2-OEM	12SE	2	225 kHz	16 / 16	2	3	OEM

### Packaging Configurations:

OEM — Board-level embedded version for maximum flexibility. Power supply not included.

BNC — Metal box enclosure with BNCs for analog inputs. If you select a model with analog outputs, BNCs are provided. The BNC box configuration also provides 4 BNCs for connecting external clocks and triggers. Power supply and cable included.

### ACCESSORIES

- **BNC DIN Rail Kit** — Kit for mounting USB modules in BNC enclosure to a DIN rail. Includes mounting clips, screws, and instructions. DIN Rail not included.
- **EP355** — Screw terminal panel for attaching analog I/O and digital I/O signals (for OEM configurations only).
- **EP361** — A +5 V power supply (included with BNC configurations).

### FREE SOFTWARE

- **QuickDAQ**
- **DAQ Adaptor for MATLAB** — Access the analyzation and visualization tools of MATLAB®.
- **LV-Link** — Access the power of Data Translation boards through LabVIEW™.

### OPTIONAL SOFTWARE

- **QuickDAQ FFT Analysis Option** (License Required)
- **QuickDAQ Advanced FFT Analysis Option** (License Required)