

DT9824

High Stability, High Accuracy, Fully Isolated USB Data Acquisition Module

The DT9824 USB data acquisition (DAQ) module offers the **highest stability and accuracy** for measuring analog signals. Every signal input, both analog and digital, is fully isolated from each other. This technology, ISO-Channel™, guarantees that all signals are protected from any environmental or system noise.

The high stability design of these modules offer four distinct advantages:

- 10ppm accuracy
- a temperature coefficient of $\pm 0.05\mu\text{V}/^\circ\text{C}$
- a CMRR of greater than 150dB
- 1.5 ppm maximum noise

These features deliver data acquisition results that are **twenty times better** than the normal solution from another system.

These modules are **ideally suited for chromatography, seismic, weigh scale, and medical applications** where accuracy and stability are imperative. The rugged, compact module is fully powered by USB and can be used as a portable device or mounted in a rack. Includes free QuickDAQ software to get up and running quickly.

Key Features:

- **Voltage Inputs**
 - 4, simultaneous analog input channels: 24-bit resolution
 - $\pm 500\text{ V}$ galvanic isolation: ISO-Channel technology provides channel-to-channel protection...**guarantees noise immunity**
 - **Maximum flexibility for any signal input:** input ranges of $\pm 10\text{V}$, $\pm 1.25\text{V}$, $\pm 0.625\text{V}$, $\pm 0.3125\text{V}$
- **Advanced Sampling Modes**
 - **Sampling frequency:** up to 4800Hz per channel
 - **Continuously paced** analog input operations
 - **Software-programmable** trigger type
 - **Channel Gain** list allows measurement of any combination of channels/gains
- **Isolated Digital I/O**
 - 8 opto-isolated digital input lines
 - 8 opto-isolated digital output lines
 - Galvanically isolated digital I/O to 250V
 - Read the digital input port through the analog input



Figure 1. The DT9824 provides ultra-high accuracy and stability while also providing ISO-Channel protection from any noise conditions. Each analog input is galvanically isolated from any other input and has its own return path. This means that other "grounds" or return paths from other signals or from the computer have no possibility to interfere with an ISO-Channel input or return. The shielded steel enclosure, 1U by 1/2 rack, further enhances noise immunity.

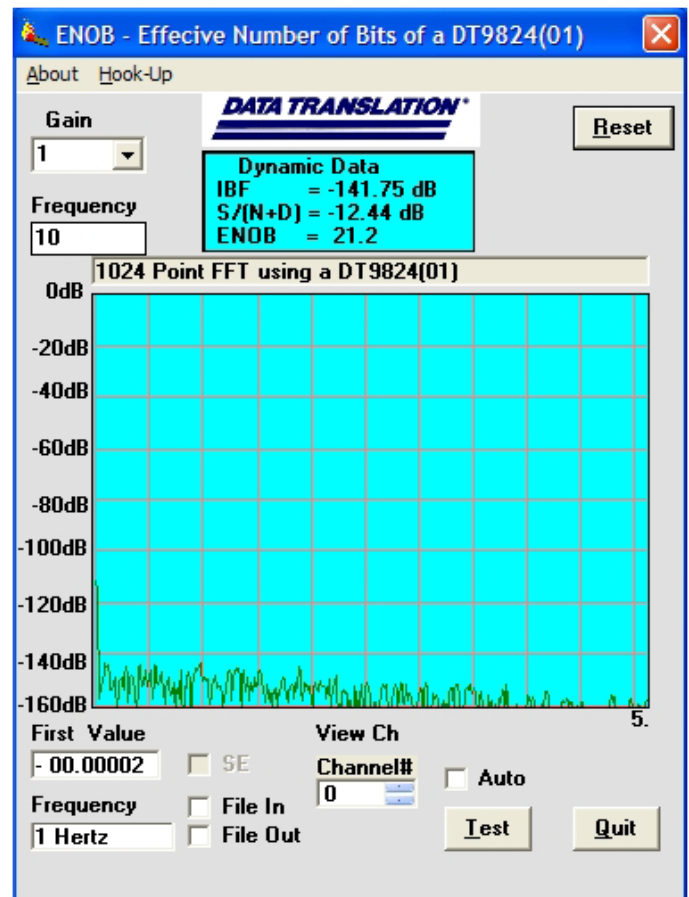

Figure 2. The ENOB (Effective Number of Bits) chart shows the low level of noise, baseline noise at better than 21 bits, with zero signal at the input (input shorted) that is generated at the output. ENOB chart is an FFT plot that points out harmonics and other error producing results. Other plots at various input ranges are shown on the following pages.

Analog Inputs

The DT9824 module supports four, simultaneous, analog input channels, configured differentially. The analog input resolution of the DT9824 module is 24 bits but programmable gains allows even greater resolution. The DT9824 module can acquire data from a single analog input channel or from a group of analog input channels. Analog input channels are numbered 1 to 4.

Input Ranges and Gains

The DT9824 module has a bipolar range of ± 10 V. In addition, there are choices of 5 gains (1, 8, 16, or 32). Table 1 lists the supported gains and effective input range of each input range on the DT9824 module.

Gain	Bipolar Input Range
1	± 10 V
8	± 1.25 V
16	± 0.625 V
32	± 0.3125 V

The DT9824 module uses offset binary data encoding for the ± 10 V bipolar range.

Triggers

A trigger is an event that occurs based on a specified set of conditions. The DT9824 module supports the following trigger sources:

- Software trigger
- External trigger

Analog Input Conversion Modes

The DT9824 module supports the following conversion modes:

- Single-value operations
- Continuous mode

The conversion rate is determined by the frequency of the A/D sample clock.

Digital Input Lines

The DT9824 module features eight, isolated, digital input lines. Digital inputs operate from +3 to +28 V DC, with a switching time of 2 ms maximum.

Digital Output Lines

The DT9824 module features eight, latched and isolated digital output lines. The outputs are solid-state relays that operate at ± 30 V and 400 mA peak (AC or DC). Switching time is 2 ms maximum.

Digital I/O Operation Modes

The following digital I/O operation modes are supported for the DT9824 module:

- Single-value operations
- Continuous

Digital I/O Channel-to-Channel Isolation

The DT9824 module includes channel-to-channel isolation of up to 250 V between digital I/O lines. Greater channel-to-channel isolation, can be achieved by using every other digital line. This reduces the number of digital I/O lines, but provides channel-to-channel isolation of 500 V (one channel can be +250 V while the adjacent channel can be -250 V).

Accessories

The following optional accessories are available for the DT9824 module:

- **STP37 screw terminal panel** — The STP37 permits easy screw terminal connections for accessing the digital I/O signals on a DT9824 module.
- **Rack-mount kits** — To rack mount a single module, order EP379, a single rack-mount kit (Data Translation part number 23610). To rack mount two modules side by side, order EP380, a dual rack-mount kit (Data Translation part number 23604).

QuickDAQ

QuickDAQ allows you to acquire and display from all Data Translation USB and Ethernet data acquisition devices that support analog input streaming. Combine QuickDAQ with Data Translation hardware to acquire data, record data to disk, display the results in both a plot and digital display, and read a recorded data file. Be productive right out of the box with this powerful data logging software. Data can be exported to other applications like Microsoft Excel® and The Mathworks MATLAB® for more advanced analysis. Two additional options can be purchased to add FFT analysis capabilities to the base package.

Key Features:

- **QuickDAQ Base Package (Free)**
 - Ready-to-measure application software
 - Configure, acquire, log, display, and analyze your data
 - Customize many aspects of the acquisition, display, and recording functions to suit your needs
- **FFT Analysis Option (License Required)**
 - Includes all the features of the QuickDAQ Base Package
 - Perform single-channel FFT operations including:
 - ◆ Auto Spectrum
 - ◆ Spectrum
 - ◆ Power Spectral Density
 - Configure and view dynamic performance statistics
 - Supports Hanning, Hamming, Bartlett, Blackman, Blackman Harris, and Flat Top response windows
- **Advanced FFT Analysis Option (License Required)**
 - Includes all the features of the QuickDAQ Base Package and FFT Analysis Package
 - Perform 2-channel FFT operations including:
 - ◆ FRF
 - ◆ Cross-Spectrum
 - ◆ Cross Power Spectral Density
 - ◆ Coherence
 - ◆ Coherent Output Power
 - Supports real, imaginary, and Nyquist display functions
 - Additional FFT analysis functions supported: Exponential, Force, Cosiner Taper
 - Save data to .uff file format

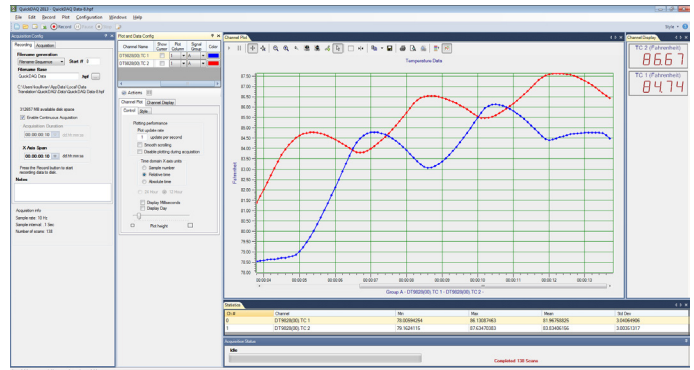

Figure 3: QuickDAQ ships free-of-charge and allows you to get up and running quickly.

Other Software Options

There are many software choices available for application development, from ready-to-measure applications to programming environments.

The following software is available for use with the DT9824 module and is provided on the Data Acquisition Omni CD:

- **DT9824 Device Driver** –The device driver allows you to use a DT9824 module with any of the supported software packages or utilities.
- **DT9824 Calibration Utility** – This utility allows you to calibrate features of a DT9824 module.
- **Quick DataAcq** application – The Quick DataAcq application provides a quick way to get up and running. Using this application, verify key features of the module, display data on the screen, and save data to disk.
- **DT-Open Layers® for .NET Class Library** – Use this class library if you want to use Visual C#® or Visual Basic® for .NET to develop application software using Visual Studio® 2003-2012; the class library complies with the DT-Open Layers standard.
- **DataAcq SDK** – Use the Data Acq SDK to use Visual Studio 6.0 and Microsoft® C or C++ to develop application software using Windows® XP/Vista/7/8; the DataAcq SDK complies with the DT-Open Layers standard.
- **DAQ Adaptor for MATLAB** – Data Translation’s DAQ Adaptor provides an interface between the MATLAB® Data Acquisition (DAQ) toolbox from The MathWorks™ and Data Translation’s DT-Open Layers architecture.
- **LV-Link** – Data Translation’s LV-Link is a library of VIs that enable LabVIEW™ programmers to access the data acquisition features of DT-Open Layers compliant USB and PCI devices.

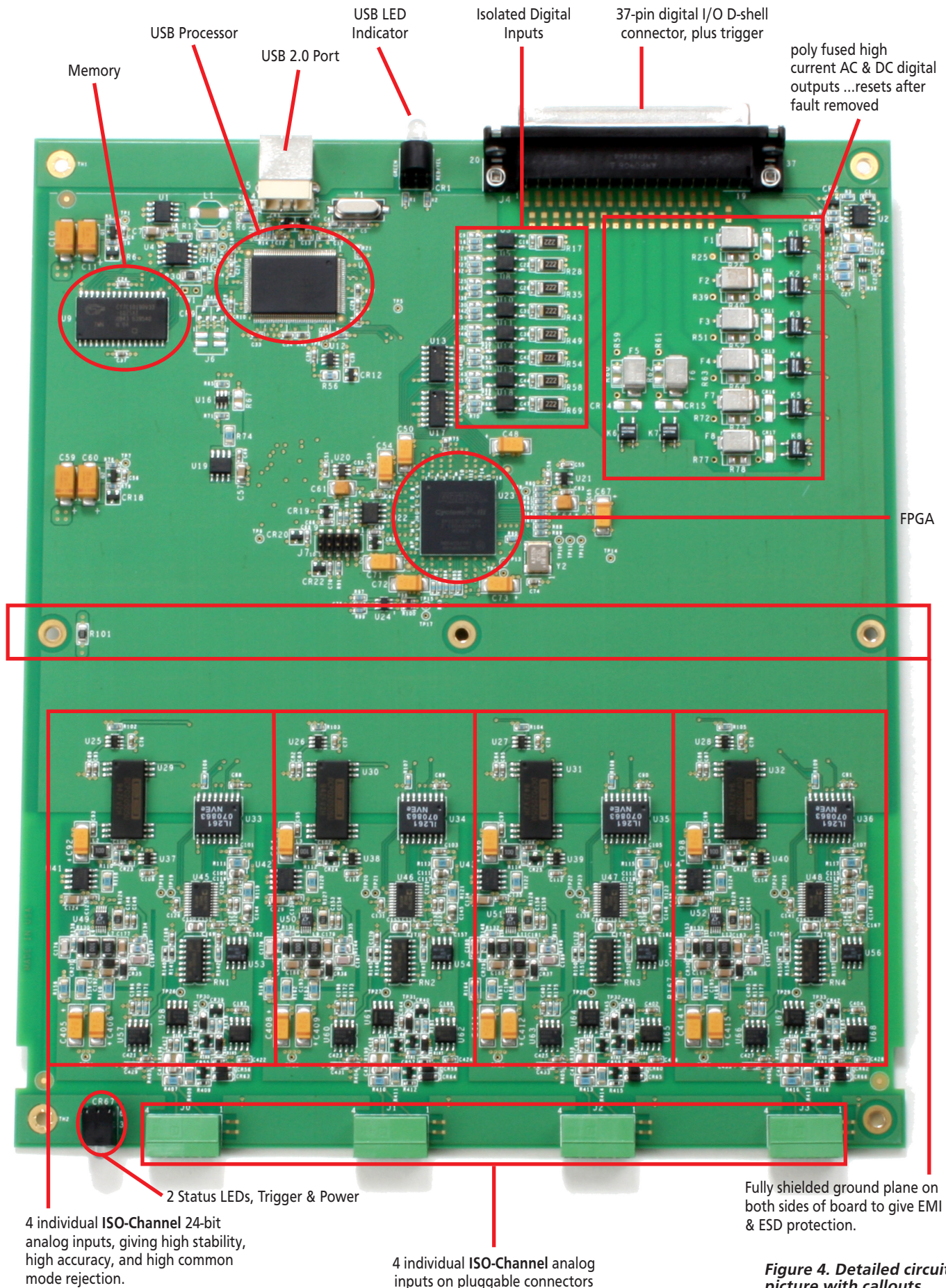

Figure 4. Detailed circuit picture with callouts.

DT9824 ISO-Channel™

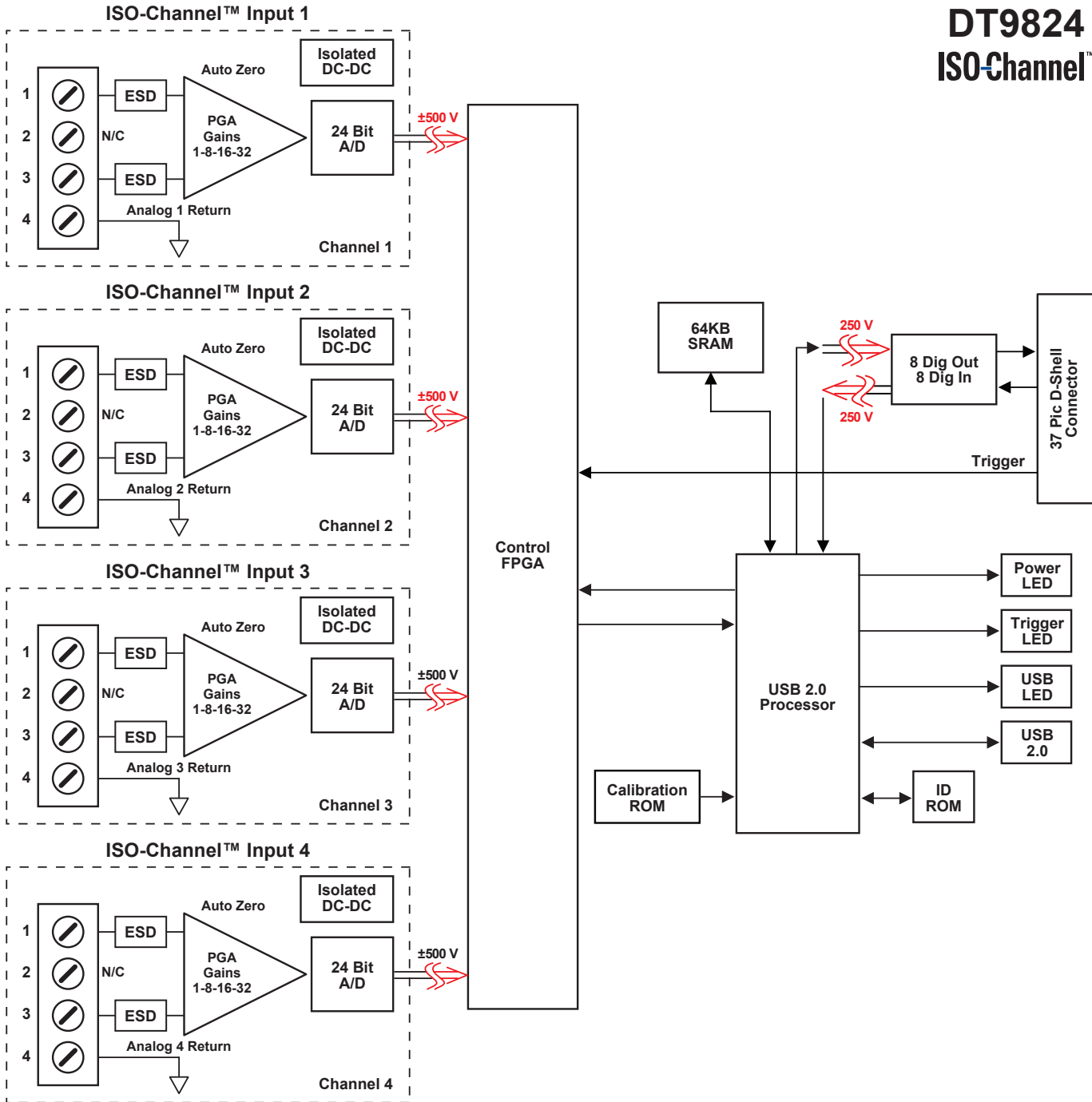
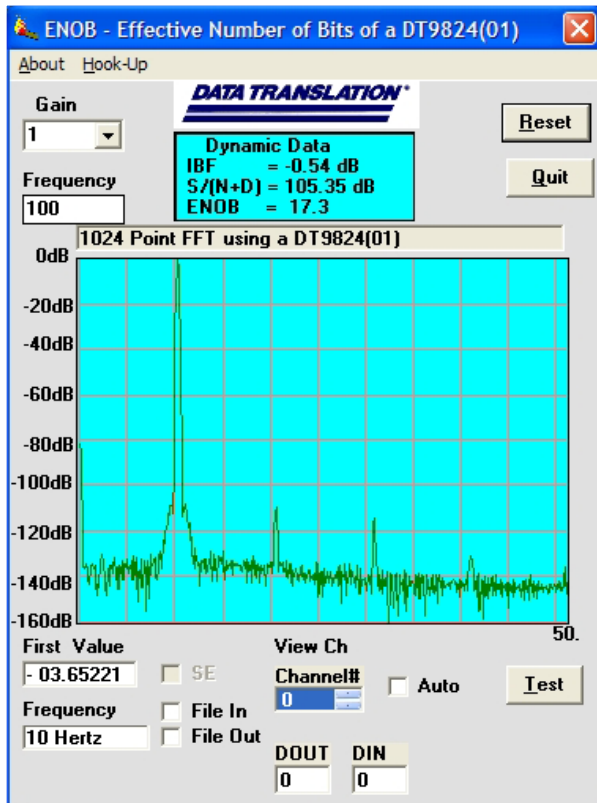
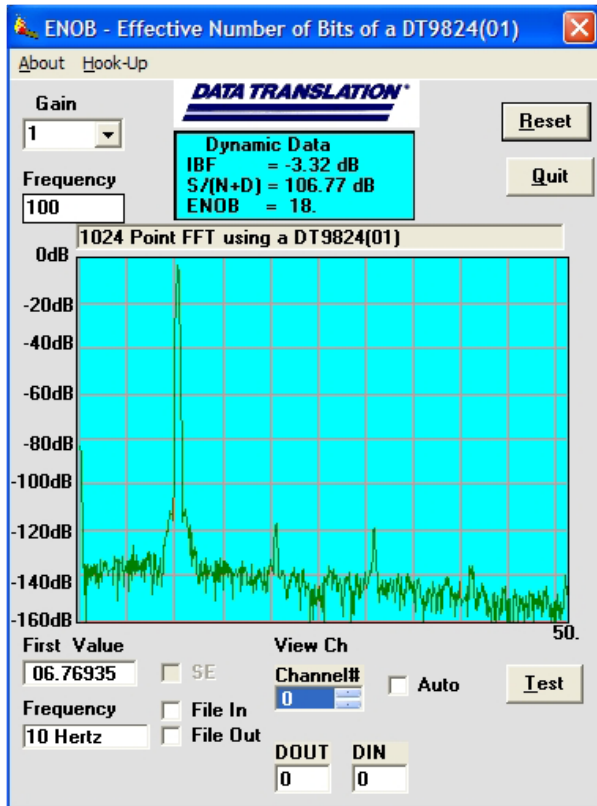

Figure 5. The DT9824 block diagram shows the 4 separate ISO-Channel analog inputs with their separate "ground" return paths. Each analog input has its own 24-bit sigma-delta A/D and auto-zero programmable gain amplifier (PGA) to achieve unprecedented stability and accuracy. CMRR is better than 150dB, system gain error of better than ±0.003%, system zero error of less than ±50uV, give accuracy and stability performance beyond any other solution.



Figures 6 & 7. ENOB results are shown for input ranges at one-half full scale (-6dB) and at full scale. The ENOBs are a small amount lower as the input range increases due to slew rate limitations on the amplifier at 18.3 bits and 17.2 bits. These are much higher than comparable solutions, giving greater accuracy and stability.

Copyright © 2016 Data Translation, Inc. All rights reserved. All trademarks are the property of their respective holders. Prices, availability, and specifications are subject to change without notice.

Ordering Summary

HARDWARE

- DT9824 – High Accuracy, Simultaneous USB Data Acquisition (DAQ) Module

ACCESSORIES

- EP379 – Dual-Rack mount kit
- EP380 – Single-Rack mount kit
- STP37 – Screw Terminal Panel

FREE SOFTWARE

- QuickDAQ
- DAQ Adaptor for MATLAB – Access the analysis and visualization tools of MATLAB®.
- LV-Link – Access the power of Data Translation boards through LabVIEW™.

OPTIONAL SOFTWARE

- QuickDAQ FFT Analysis Option (License Required)
- QuickDAQ Advanced FFT Analysis Option (License Required)