

IMPERX

BOBCAT

INTELLIGENT CAMERA SERIES

ISD-B1921



IMPERX ISD-B1921 is an advanced progressive scan, fully programmable CCD camera designed for imaging applications that require high quality images, powerful features and flexibility. The camera is small, light weight, and built around Kodak's KAI-02150 5.5 micron Interline Transfer CCD image sensor with a 2/3" optical format.

The ISD-B1921 provides an image resolution of 1920 x 1080 and delivers 25/30 frames per second at full resolution. The camera's 14 bit internal data image processing engine is based on an industrial grade high-speed, high-density FPGA, enabling a broad standard feature set and easy implementation of demanding custom imaging solutions. The thermally optimized, mechanical and electrical design plus the extended operating temperature range (-40°C to +85°C), and high MTBF of 660,000 hrs @ 40C, make this HD-SDI camera a perfect fit for the most demanding industrial, medical, scientific and military applications. This camera is also available with CoaXPress, Camera Link®, or GigE Vision® interfaces.

Features

- 1920/1080 @30 frames per second
- Mono, color
- 24p, 25p, 50i, 30(29.97)p, 60(59.94)i
- HD-SDI
- RS232 and RS485 serial communication
- Analog and digital gain and offset control
- Six (6) independent horizontal and vertical AOIs
- Programmable frame time and speed
- Programmable external trigger (optional)
- Internal/External exposure control
- Automatic gain, exposure and iris control
- Automatic white balance
- Internal/External H and V sync input/output

- Left/right digital bit shift
- Test image with image superimposition
- Built in pulse generator
- Programmable I/O mapping
- Dynamic transfer function correction
- Dynamic black level correction
- Defective and hot pixel correction (static/dynamic)
- Temperature monitor
- Field upgradeable firmware
- Customer defined Look Up Table (LUT)
- Two dimensional Flat Field Correction
- Reverse image (H mirror)
- MTBF of 660,000 hours @ 40°C

APPLICATIONS

- Aerial Mapping
- Aerial Robots: Military, Police
- Aerospace
- Agriculture
- Automation

- Automotive
- Biometrics
- Broadcasting
- Printed Circuit Board (PCB)
- Electronics
- Energy/Solar/Wind Power

- Flat Panel Inspection
- Food/Beverage
- Homeland Security
- Law Enforcement
- Intelligent Traffic Systems (ITS)
- Medical Devices/Imaging

- Metrology
- Microscopy
- Military/Defense
- Pharmaceuticals
- Particle Image Velocimetry (PIV)
- Radiology

- Robotics
- Scientific Apps
- Surveillance
- Semiconductors
- Transportation
- Textile/Apparel



BOBCAT ISD-B1921 Specifications

Sensor Type	1920 x 1080
Pixel Size	2/3" CCD KAI-02150
Frame Rate	5.5 μ m
Minimum S/N ratio	25/30 fps
Video Output	60 db
Horizontal Frequency	Digital HD-SDI (SMPTE 292), 1080i, 1080p
Vertical Frequency	33.75/33.716 KHz
Area of Interest	30.00/29.97 Hz, 60.00/59.94 Hz
Shutter Speed	6 independent AOIs, 2 x 2 to 1920 x 1080
Long Integration	1/100,000 to 1/30 sec (nom)
Gamma Correction	Up to 16 sec
Video Gain	G=1.0, G= 0.45, user upgradable LUT
Exposure and AGC	36 dB range, 1024 steps, 0.0351 dB per step
Iris Control	Manual, Auto, Programmable
	Auto, Programmable

Strobe Output	Programmable position and duration
Image Overlay	Yes, Programmable
RS232/RS485 Interface	Yes
Data Corrections	DPC, HPC, LUT, FFC
Min. Illumination	1 Lux, F/1.4
Supply Input Range	12 VDC, (10V min, 15V max)
Power Consumption	4.5W, 370mA steady, 1.5 A inrush
Size (W x H x L)	46 x 46 x 69.85mm
Weight	250g
Lens Mount	C mount
Vibration, Shock	10G (20 - 200) Hz XYZ, 70G
Environmental	Operation (-40° to +85°)C
	Storage (-40° to +90°)C
Humidity	10% to 90% non-condensing
MTBF	660,000 hrs. @ 40°C
Regulatory	FCC 15 part A, CE, RoHS

1	12V DC Return	7	OUT1 Signal
2	+12V DC	8	IN1 Signal
3	IRIS VCC	9	IN2 Signal
4	IRIS Video	10	IN1/2 Return
5	IRIS Return	11	Reserved
6	OUT1/2 Return	12	OUT2 Signal

Connector: Hirose HR 10A-10R-12PB(71)

Power and I/O Interface:

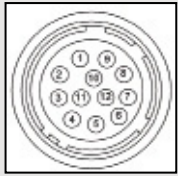

1	12V DC Return	7	OUT1 Signal
2	+12V DC	8	IN1 Signal
3	IRIS VCC	9	IN2 Signal
4	IRIS Video	10	IN1/2 Return
5	IRIS Return	11	Reserved
6	OUT1/2 Return	12	OUT2 Signal

Connector: Hirose HR 10A-10R-12PB(71)

Lens Control:

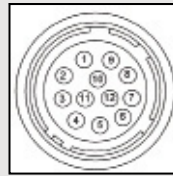

1	RX 485 COM	7	Lens CTRL4
2	RX 485 +	8	Lens CTRL5
3	RX 485 -	9	Lens CTRL6
4	Lens CTRL1	10	RS 232 COM
5	Lens CTRL2	11	RS 232 RX
6	Lens CTRL3	12	RS 232 TX

Connector: Hirose HR 10A-10R-12SB(71)

Accessories: PS12V04: Power Supply (sold separately)

Order Options: ISD-B1921M-KCO Monochrome HD-SDI Output
ISD-B1921C-KCO Color HD-SDI Output

For specific details and ordering information, consult the camera user's manual or contact IMPERX at sales@imperx.com.

Spectral Response

Software/Drivers/Interface

Mechanical Dimensions

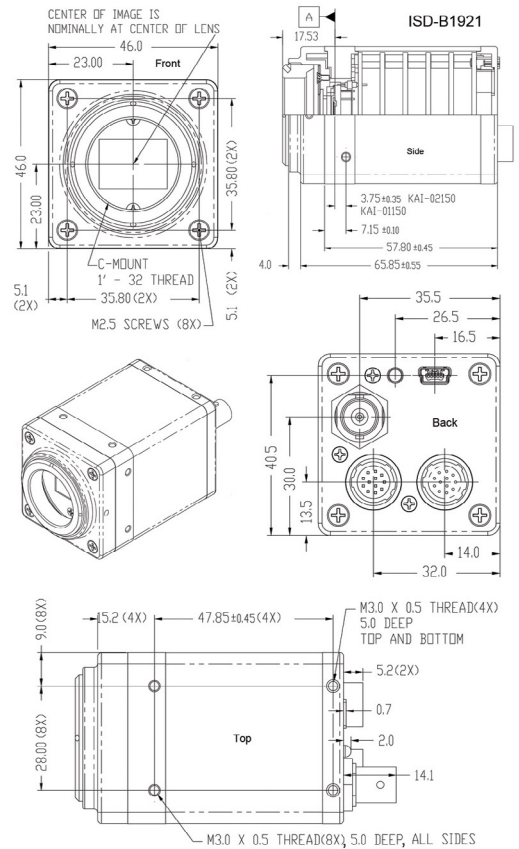
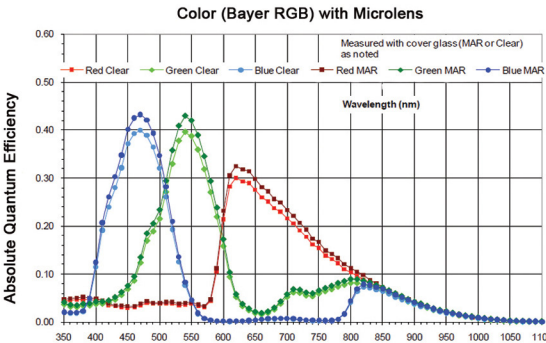
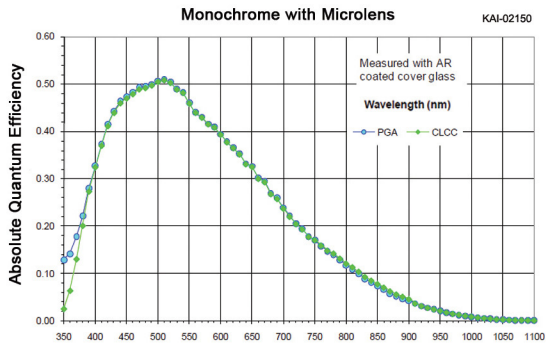

Note: Datum "A" refers to the imaging plane of sensors: KAI-01150 and KAI-02150



Société SAIS
2 rue Henri Janin
78470 ST REMY LES CHEVREUSE

Tel : 09 54 16 23 53 - Fax : 09 59 16 23 53

contact@sacasa.info - www.sacasa.info

