

5B34 Isolated, Linearized RTD Input

Functional Description

The 5B34 is a single-channel signal conditioning module that amplifies, protects, filters, linearizes and isolates a wide variety of two- and three-wire RTDs. For true four-wire RTD measurements please refer to the 5B35 section.

The 5B34 protects the computer side from damage due to field-side overvoltage faults. The module withstands 240 V rms at the input terminals without damage thereby shielding the internal computer-side circuitry from field-side overvoltage conditions. In addition, the 5B34 is mix-and-match and hot swappable with all other 5B Series input modules, so can be inserted or removed from any socket in the same backplane without disrupting system power.



Inside the 5B32 Series Module

Two identical sources provide excitation current for the RTD. For three-wire RTDs, the second current flows through the third RTD lead so as to cancel the effects of (equal) lead resistance; this current also flows through a stable resistor laser-trimmed to the RTD value that sets the differential amplifier input and (module) output to zero volts at that scale point. The current sources and the amplifier input are protected to withstand input overvoltage up to 240 V rms.

A differential chopper-stabilized input amplifier provides stable gain and exceptionally low drift. This allows the use of very low RTD excitation current to minimize self-heating and preserve measurement accuracy. Along with module gain and zero settings, a feedback linearizer is laser-trimmed. Custom versions of 5B34 can be laser-trimmed to meet special requirements.

Internal multi-pole lowpass filtering with a four-Hz cutoff (-3dB) enhances normal-mode (noise on signal) and common-mode (noise on signal return) rejection at 50/60 Hz, enabling accurate measurement of small signals in high electrical noise.

Signal isolation by transformer coupling uses a proprietary modulation technique for linear, stable and reliable performance. The differential input circuit on the field side is fully floating, eliminating the need for any input grounding. A demodulator on the computer side of the signal transformer recovers the original signal, which is then filtered and buffered to provide a low-noise, low-impedance output signal. The output common must be kept within ±3 V of power common.

Convenience Features

A series output switch eliminates the need for external multiplexing in many applications. The switch is turned on by an active-low enable input. If the switch is to be on at all times, the enable-input should be grounded to power common as it is on the 5B01 and 5B08 backplanes.

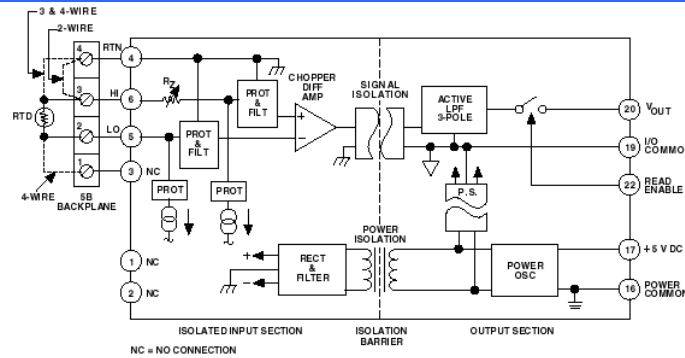

Figure 1. 5B34 Functional Block Diagram

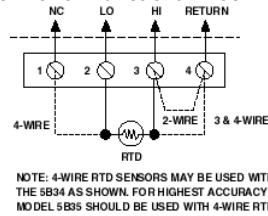

Figure 2. 5B34 Input Field Connections

Input Ranges	Output Ranges
100 Ω Platinum RTD	0 to +5 V
10 Ω Copper RTD	
120 Ω Nickel RTD	

5B34 Models Available

Model			
5B34-01	100 Ω Platinum, $\alpha = 0.00385^*$ -100°C to +100°C (-148°F to +212°F)	0 V to +5 V	$\pm 0.32^\circ\text{C}$
5B34-02	0°C to +100°C (+32°F to 212°F)	0 V to +5 V	$\pm 0.13^\circ\text{C}$
5B34-03	0°C to +200°C (+32°F to 392°F)	0 V to +5 V	$\pm 0.26^\circ\text{C}$
5B34-04	0°C to +600°C (+32°F to 1112°F)	0 V to +5 V	$\pm 0.78^\circ\text{C}$
5B34-C-01	10 Ω Copper, $\alpha = 0.004274$ 0°C to +120°C (10 Ω @ 0°C) (+32°F to +248°F)	0 V to +5 V	$\pm 0.23^\circ\text{C}$
5B34-C-02	0°C to +120°C (10 Ω @ 25°C)(+32°F to +248°F)	0 V to +5 V	$\pm 0.23^\circ\text{C}$
5B34-N-01	120 Ω Nickel, $\alpha = 0.00672$ 0°C to +300°C (+32°F to +572°F)	0 V to +5 V	$\pm 0.40^\circ\text{C}$
5B34-Custom	*	*	

* Custom Input/Output ranges are available including versions for the 100 Ω Platinum RTD with $\alpha = 0.003916$. Refer to configuration guide.

5B34 Specifications

(typical @ +25°C and $V_s = +5$ V dc)

Description	Model 5B34
Input Ranges	
Standard Ranges	Refer to Model Table
Custom Ranges	-200°C to +850°C (100 Ω Platinum) -80°C to +320°C (120 Ω Nickel) -100°C to +260°C (10 Ω Copper)
Output Range ($R_L > 50$ k Ω)	0 V to +5 V
Accuracy²	
Initial @ +25°C	$\pm 0.05\%$ Span ± 0.04 Ω * ± 0.05 (Rz^1)
Conformity Error ³	$\pm 0.05\%$ Span
Input Offset vs. Temperature	$\pm 0.02^\circ\text{C}/^\circ\text{C}$
Output Offset vs. Temperature	± 20 $\mu\text{V}/^\circ\text{C}$
Gain vs. Temperature	$\pm 0.005\%$ of Reading/ $^\circ\text{C}$
Input Bias Current	± 3 Na
Input Resistance	
Power On	5 M Ω
Power Off	40 k Ω
Overload	40 k Ω
Noise	
Input, 0.1 Hz to 10 Hz Bandwidth	0.2 μV rms
Output, 100 kHz Bandwidth	200 μV rms
Bandwidth, -3 dB	4 Hz
Output Rise Time, 10% to 90% Span	200 ms
Common-Mode Voltage (CMV)	
Input-to-Output, Continuous	1500 V rms, maximum
Output-to-Power, Continuous ⁴	± 3 V, maximum
Transient	ANSI/IEEE C37.90.1-1989
Common Mode Rejection (CMR)	
1 k Ω Source Imbalance 50/60 Hz	160 dB

Normal Mode Rejection 50/60 Hz	60 dB
Sensor Excitation Current	
100 Ω Pt, 120 Ω Ni	0.25 mA
10 Ω Cu	1.0 mA
Lead Resistance Effect	
100 Ω Pt, 120 Ω Ni	$\pm 0.02^\circ\text{C}/\Omega$
10 Ω Cu	$\pm 0.2^\circ\text{C}/\Omega$
Input Protection	
Continuous	240 V rms, maximum
Transient	ANSI/IEEE C37.90.1-1989
Output Resistance	50 Ω
Voltage Output Protection	Continuous Short to Ground
Output Selection Time	6 μs @ $C_{\text{load}} = 0$ to 2,000 pF
Output Enable Control	
Max Logic "0"	+1 V
Min Logic "1"	+2.5 V
Max Logic "1"	+36 V
Input Current "0"	0.4 mA
Power Supply Voltage	+5 V $\pm 5\%$
Power Supply Current	30 mA
Power Supply Sensitivity, RTI	
100 Ω Pt, 120 Ω Ni	$\pm 0.05^\circ\text{C}/\text{V}$
10 Ω Cu	$\pm 0.5^\circ\text{C}/\text{V}$
Mechanical Dimensions	2.275" x 2.375" x 0.595" (57.8 mm x 59.1 mm x 15.1 mm)
Environmental	
Temperature Range	
Rated Performance	-25°C to +85°C
Operating	-40°C to +85°C
Storage	-40°C to +85°C
Relative Humidity	0 to 93% @ +40°C noncondensing
RFI Susceptibility	$\pm 0.5\%$ Span error @ 400 MHz, 5 Watt, 3 ft

* $\pm 0.025 \Omega$ For Cu RTD's; $\pm 0.1 \Omega$ For Ni RTD's.

¹ Rz is the value of the RTD resistance at the lowest point of the measurement range.

² Includes the combined effects of repeatability, hysteresis,

and conformity error. Loads heavier than 50 k Ω will degrade conformity and gain temperature coefficient.

³ For Pt RTD's only; other types may vary.

⁴ The output common must be kept within ± 3 V of power common.